



3170 Wasson Road • Cincinnati, OH 45209 USA  
Phone 513-533-5600 • Fax 513-871-0105  
foodandbev@richardsind.com • www.steriflowfoodandbev.com

## I & M FB5CPM Series

### Installation & Maintenance Instructions for FB5CPM Sanitary Back Pressure Regulators

**Warning:** Steriflow Food and Beverage Sanitary Pressure Regulators must only be used, installed and repaired in accordance with these Installation & Maintenance Instructions. Observe all applicable public and company codes and regulations. In the event of leakage or other malfunction, call a qualified service person; continued operation may cause system failure or a general hazard. Before servicing any valve, disconnect, shut off, or bypass all pressurized fluid. Before disassembling a valve, be sure to release all spring tension.

#### Please read these instructions carefully!

Your Steriflow Food and Beverage product will provide you with long, trouble-free service if it is correctly installed and maintained. Spending a few minutes now reading these instructions can save hours of trouble and downtime later. When making repairs, use only genuine Steriflow Food and Beverage parts, available for immediate shipment from the factory.

### Introduction

The FB5CPM is an air loaded, remote operated, sanitary back pressure regulating valve (BPRV). Users can manually adjust the set pressure by air loading the dome, with an adjustable air regulator, or I/P.

Traditional sanitary BPRV's are normally operated with only a manual adjustment knob that adds or subtracts tension to a spring that sits on a platform on top of a diaphragm whose opposite side is connected to a stem and valve plug. The opposite (process side) of the diaphragm is exposed to the inlet side of the valve (downstream pressure). Increasing the tension on the spring moves the diaphragm and stem in the closing direction, conversely increasing the upstream pressure. Stated another way, increasing the spring tension, increases the valve's outlet pressure set point; and decreasing the spring tension, decreases the set point pressure.

Sanitary BPRV's are typically installed several feet above grade and are usually not easily accessible because of the installation height, or obstructions, or because of their location in a clean room manufacturing suite. Typical installation or adjustment involves the time of at least one technician to manually adjust the regulator for system operating pressure changes (balancing pressures during initial system commissioning, or for changing valve stem position during operation for CIP, for example).

*The FB5CPM was invented to solve this access problem. It uses a remote mounted, adjustable air pressure source instead of a manually adjusted spring to apply force to the diaphragm stem and plug. Increasing the air pressure*

*on top of the diaphragm, increase the valve's outlet set point pressure, and decreasing the pressure, lowers the outlet pressure set point.*

To enable the valve's operation and adjustment, an air line is connected to the 1/4" air inlet (22) and an air regulator\* (remotely installed at grade) is used to adjust the FB5CPM set point. Alternatively, the FB5CPM is also offered with an I/P option, allowing the user to remotely drive the air pressure with a 4-20 mA signal from distributed control system (DCS) or PLC logic.

\* air regulator must be a self-relieving type

### Ideal Installation

Refer to FB5CPM Illustrated Parts List on Page 5.

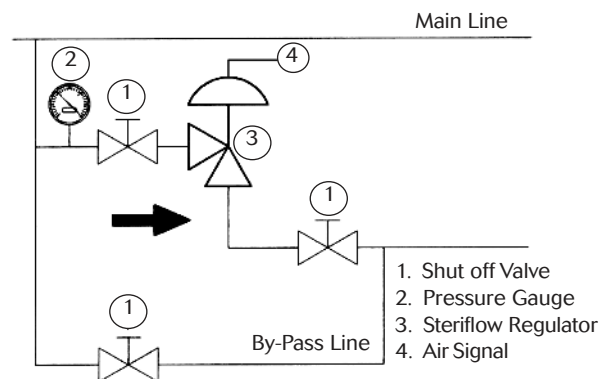

1. The valve is designed for sanitary service and it is assumed that it will be installed into a clean tubing system. Under these conditions, special considerations to protect the valve such as providing line strainers at the valve inlet are not necessary.
2. The regulator should be installed with the outlet (bottom of valve) vertical and the inlet horizontal. This orientation allows unhindered drainage (zero holdup). Please note the valve will function in any position, but for best drainage, the valve must be installed with the vertical axis sloped 2 degrees toward or away from the inlet port to facilitate drainability
3. Steam regulators are best located at the highest point in the piping with the take-off out of the top of steam header, or vertical riser on a distribution leg. This will minimize the possibility of retained water in the regulators flow stream.

4. For best control, 3' 0" straight sections of pipe should be installed on either side of the regulator to insure a non-turbulent flow profile.
5. In order to accurately set a pressure regulator, a gauge pressure instrument should be installed at the regulator inlet. The ideal installation is at least three pipe diameters upstream of the regulator.
6. If possible, install a relief valve upstream from the regulator. Set at about 30% above the control point of the regulator.
7. Use caution in tightening commercial sanitary fittings. Over-tightening can cause the gasket to extrude into the flow passage.
8. Operate the FB5CPM within its pressure and temperature rating as stamped on the valve nameplate.
9. **If using an air regulator with your FB5CPM:** *Safety Note: Only select tubing, tube fittings and other airline components with a design pressure allowing their safe use at pressures up to your air systems maximum pressure rating. Make sure the air regulator or I/P you select will not have any chance to overload the FB5CPM diaphragm. The maximum air loading pressure for your FB5CPM can be found in the chart below.*

FB5CPM Connection	Maximum Allowable Pressure Setpoint
3/4" - 1"	105 psi (7,2 bar)
1-1/2"	85 psi (5,9 bar)
2"	60 psi (4,1 bar)

Select an air regulator with an appropriate outlet air pressure range, one that is a self-relieving type, and preferably one that has an outlet gauge. Install a 1/4" tube fitting into the 1/4" FNPT air inlet (37) on the side of the FB5CPM. Connect an appropriate length of 1/4" tubing and connect the other end to a tube fitting installed in the outlet of the air pressure regulator installed at an accessible grade location. Install a shut off valve upstream of the air regulator in the inlet side tubing.

10. **If using an I/P with your FB5CPM:** *Make sure the I/P selected has the proper NEMA or IS rating classification for the installation area, or install in a cabinet with the proper classification. See also safety notes under # 9.* Connect the tubing with the same components, and in the same manner as described above in 9. Connect the wiring to the nearest I/P terminal in the manner following the manufacturer's instructions, local electrical code and local best practice. Follow the installation, operation, maintenance and safety instructions that come with your I/P.
11. **Safety Note:** Test the Integrity of the airlines you just installed. Double check all tube fittings and connections to make sure all are tight, and secure

enough to handle a pressure up to your air system's maximum pressure rating. Lastly, pressurize the lines to the maximum pressure that they can see.

---

## Set-Up and Start-Up

---

**Safety Note: The following procedures will affect process pressure. Take appropriate action to ensure process and personnel safety.**

1. Make sure all FB5CPM process connections are secure for their rated pressure, and that all installation instructions have been followed.
2. Fully open the process line block valve downstream of the regulator.
3. Slowly open the block valve installed immediately upstream of the regulator.
4. Slowly open and close the upstream block valve several times; this will stroke the valve and confirm satisfactory operation.
5. **Using a remote mounted air pressure regulator:** Note: the FB5CPM inlet block valve must be open to perform the following procedure. Slowly increase the air pressure into the spring housing by adjusting the air regulator knob (following adjustment instructions in the regulator's installation manual) until the process pressure upstream of the FB5CPM reaches the desired value. Record the air regulator set point in appropriate documents or in the control system information database.
6. **Using an I/P:** Most DCS or PLC HMI systems allow for manual override of output current (4-20 Ma output). If that is not possible, the I/P wiring can be disconnected, and a process loop calibrator can be used to artificially drive the I/P to varied outputs. Configure the I/P following the manufacturer's instructions. To adjust the FB5CPM setpoint, slowly increase the spring housing pressure by driving the I/P's Ma input to a value that produces the desired FB5CPM inlet pressure. Record the Ma setpoint value that produces the desired FB5CPM inlet pressure. Record the Ma setpoint value for proper document, or in the control system information database.

---

## Maintenance

---

**Caution: Make certain that there is no pressure in the valve before loosening any fittings or joints. The following steps are recommended:**

1. Close the air supply valve to the FB5CPM air regulator or I/P. Carefully vent any air in the upper housing (14).
2. Close the block valve upstream of the regulator inlet.
3. Allow pressure to bleed off through downstream piping. Do not attempt to reverse the flow through the valve by bleeding pressure from the regulator outlet to the inlet side.
4. When the upstream and downstream pressure gauges indicate that all pressure has been removed from the system, remove the air load or disconnect the I/P following the device's maintenance manual. The valve can now be serviced.

**Note: Refer to the FB5CPM illustrated parts list on page 4 for description and proper orientation of parts.**

---

## Disassembling the Valve

---

### **3/4" thru 2" FB5CPM**

1. Ensure that the valve is not pressureized by the following "Caution" at the beginning of the Maintenance Section
2. Remove the air load
3. Remove the upper housing (9) by removing the HHCS's (12)
4. Remove the hex jam nut (11) from the stem (2)
5. Remove the upper diaphragm plate (13)
6. Remove the diaphragm (4) and lower diaphragm plate
7. Remove all O-rings (5) (6) (7) (8)

---

## Preparing the Valve for Assembly

---

1. All parts should be cleaned and examined. Damaged parts should be replaced.
2. O-ring should be lubricated. They may be lubricated with any lubricant that is compatible with both your process and the o-ring material. EPDM o-rings must not be exposed to mineral oil as it will cause them to swell and make them difficult to install.

---

## Assembling the Valve

---

### **3/4" thru 2" FB5CPM**

1. Lubricate O-ring (7) and install onto the stem
2. Install lower diaphragm plate (13) onto the stem (2). Lubricate O-ring (5) and install into the groove in the lower diaphragm plate (13)
3. Install diaphragm (4) onto stem (2)
4. Lubricate O-ring (6) and install on upper diaphragm plate (3) and
5. Install upper diaphragm plate (3) onto stem (2).
6. Lubricate and install cylinder O-rings (8)
7. Install lock washer (10) and hex jam nut (11)
8. Center diaphragm (4) onto body (1).
9. Install upper housing (9)
10. Hand tighten HHCS's (12)
11. Torque HHCS's (12) to 200 in-lbs.

---

## Troubleshooting

---

### **If You Experience Erratic Control:**

- Oversizing causes cycling or hunting, and reduces the rangeability of the valve. Make certain that your sizing is correct.
- Steam traps may require maintenance.
- Safety valve may be defective.
- Valve seat in FB5CPM may be defective – replace stem (2) and/or body (1).
- Valve plug in FB5CPM may not be moving freely. Inspect bushing (38) and replace if required.

### **Upstream Pressure Build-Up:**

- Valve seat in FB5CPM may be defective – replace stem (2) and/or body (1).
- Valve plug in FB5CPM may not be moving freely. Inspect bushing (38) and replace if required.
- Diaphragm in FB5CPM may have failed; replace diaphragm if necessary.
- If FB5CPM is equipped with hard seat, consider replacing with soft seat for tighter shutoff.

### **Cannot Maintain Regulated Pressure:**

- Piping may be blocked or inadequately sized.
- Inlet pressure may be set too low.
- Spring may be broken or set too low; check setting; replace spring if broken.
- Valve may be undersized for required flow; make certain that your sizing is correct.
- System demand exceeds pump or boiler capacity.

## FB5CPM Illustration and Parts List

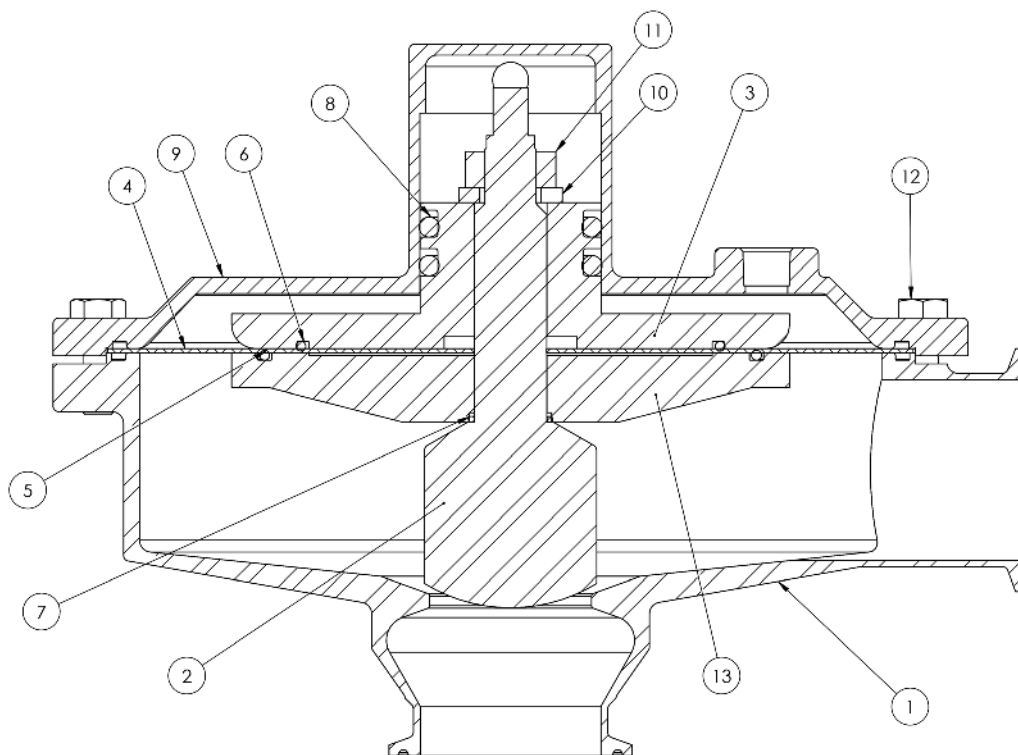

NO.	DESCRIPTION	QTY
1	BODY S/A	1
2	STEM	1
3	UPPER DIAPHRAGM PLATE	1
4	DIAPHRAGM	1
5	O-RING	1
6	O-RING UDP	1
7	O-RING STEM	1
8	O-RING CYLINDER	2
9	UPPER HOUSING	1
10	LOCKWASHER	1
11	HEX JAM NUT	1
12	HHCS	12
13	LOWER DIAPHRAGM PLATE	1