



3170 Wasson Road • Cincinnati, OH 45209 USA
Phone 513-533-5600 • Fax 513-871-0105
steriflow@richardsind.com • www.steriflowvalve.com

I & M FB5C

Installation & Maintenance Instructions for FB5C Sanitary Back Pressure Regulators

Warning: Steriflow Sanitary Pressure Regulators must only be used, installed and repaired in accordance with these Installation & Maintenance Instructions. Observe all applicable public and company codes and regulations. In the event of leakage or other malfunction, call a qualified service person; continued operation may cause system failure or a general hazard. Before servicing any valve, disconnect, shut off, or bypass all pressurized fluid. Before disassembling a valve, be sure to release all spring tension.

Please read these instructions carefully!

Your Steriflow product will provide you with long, trouble-free service if it is correctly installed and maintained. Spending a few minutes now reading these instructions can save hours of trouble and downtime later. When making repairs, use only genuine Jordan Valve parts, available for immediate shipment from the factory.

Ideal Installation

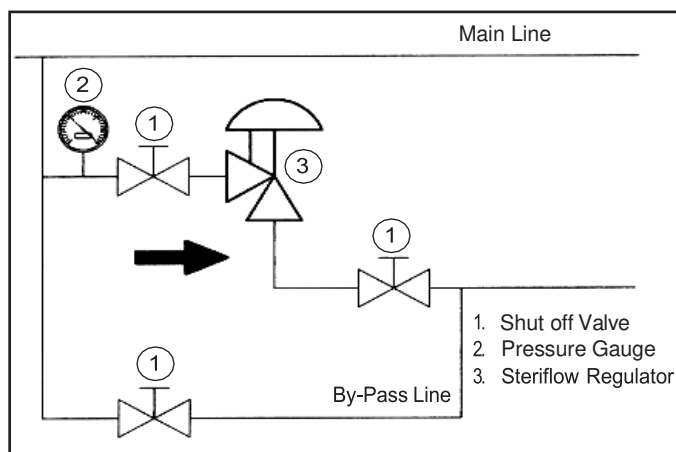

1. The valve is designed for sanitary service and it is assumed that it will be installed into a clean system. Under these conditions, special considerations to protect the valve such as providing line strainers at the valve inlet are not necessary.
2. The regulator is to be installed with the inlet horizontal and the outlet pointed down, but for best drainage, install at a 2° angle. These restrictions apply only for drainage considerations; the valve will function in any position. Contact factory for other possible orientations.
3. Steam regulators are best located at the highest point in the piping with the take-off out of the top of the steam header. This will minimize the possibility of water in the regulator.
4. For best control, 3' 0" straight sections of pipe should be installed on either side of the regulator.
5. Use caution in tightening commercial sanitary fit-

tings. Over-tightening can cause the gasket to extrude into the flow passage.

6. If possible, install a relief valve downstream from the regulator. Set at about 30% above the control point of the regulator.
7. Operate the regulator within its pressure and temperature rating as stamped on the valve nameplate.

Start-Up

1. Slowly open the inlet shutoff valve and slowly turn the adjusting screw until the desired inlet pressure is shown on the inlet pressure gauge, without discharging fluid.
2. To change the controlled pressure, turn the adjusting screw clockwise to increase the pressure, or counterclockwise to decrease the pressure.
3. Once the desired setpoint is obtained, run the thumblock down until it reaches the top of the spring housing. Then run the hex jam nut down to the top of the thumblock and lock the two together. This will effectively keep the adjusting screw from turning due to vibration, etc. This is useful during the cleaning cycle (see section on Clean-In-Place/Steam-In-Place.)

Warning: Never substitute a longer length adjusting screw. The valve may fail to open and personal injury or property damage could occur.

Maintenance

Caution: Make certain that there is no pressure in the valve before loosening any fittings or joints. The following steps are recommended:

1. Close the inlet shutoff valve.
2. Turn the adjusting screw counterclockwise until there is no pressure on the spring, allowing any trapped pressure to release downstream.
3. Allow pressure to bleed off through the downstream piping. Do not attempt to reverse the flow through the valve by bleeding pressure from the upstream side of the valve.

PROTECT VALVES WITH LINE STRAINERS

4. When the pressure gauges indicate that all pressure has been removed from the system, close the outlet shutoff valve. The valve may be removed from the line and serviced.

Note: refer to the drawing at the end of this document for description and proper orientation of parts.

Clean-In-Place

To allow the valve to open for cleaning, back off the adjusting screw to remove all range spring load. Maintain the position of the thumb-lock and hex jam nut on the stem so that the adjusting screw can be returned to its normal position to maintain the set point. After cleaning return the adjusting screw back to the original set point by using the thumb-lock and an indicator.

NOTE: 2" Valves do not use a thumb-lock, but instead use two jam nuts.

Disassembling the Valve

1. Insure that the valve is not pressurized by following the Caution note at the beginning of the Maintenance section.
2. Back off the adjusting screw subassembly (13) to remove the load from the range spring (9).
3. Remove the spring housing (11) by removing the clamp (17).
4. Remove the cylinder (8) from the spring housing (11) by rotating it approximately 90°.
5. Remove the spring (9) and spring guide (10).
6. Remove the hex jam nut (7).
7. Remove the spacer (5), upper diaphragm plate (3), diaphragm gasket (only included on 1/2" - 1" models with a 3-8 psi (0,2-0,5 bar) spring range), and diaphragm (4) from the stem (2). Remove the lower diaphragm plate (15) and o-ring (14) where applicable.
8. Remove the stem (2) from the body (1).

Preparing Valve For Assembly

1. All parts should be cleaned and examined. Damaged parts should be replaced.
2. Do not lubricate o-rings.

NOTE: For all assembly lubrication requirements, Steriflow uses Bostik NEVER_SEEZ, White Food Grade with PTFE, Cat. No. NSW-14 (improved version without mineral oils). Never use lubricant on any component below the diaphragm.

Assembling the Valve

1. Install stem (2) into body (1).
2. Install diaphragm (4) onto stem (2). Center diaphragm onto body (1).
3. Install diaphragm gasket (only included on 1/2" - 1" models with a 3-8 psi (0,2 -0,5 bar) spring range).
4. Install upper diaphragm plate (3) onto stem (2).
5. Install spacer (5) onto stem (2) as needed to obtain stroke.
6. Install lockwasher (6) & hex jam nut (7) onto stem (2) and tighten only 1/4 turn. Apply Loctite Primer 7649 and Sealant 2046 (following Loctite's instructions) to threads to lock the joint.
7. Install spring (9) into the cylinder (8).
8. Install spring guide (10) onto the spring (9).
9. Lubricate the O.D. surfaces of the cylinder (8) and install the spring housing (11). Rotate the cylinder (8) about 90° to engage the bayonet lugs.
10. Center diaphragm (4) onto body (1). Install spring housing (11) onto the body (1).
11. Secure spring housing (11) to the body (1):
 - Clamped assemblies with two bolts: torque hex nuts (not shown) to 240 inch-pounds (20 foot-pounds).
 - Clamp assemblies with wing nut: torque wing nut (not shown) to 25 inch-pounds (2 foot-pounds)
12. Install thumb-lock (12) onto the adjusting screw (13).
13. Install nameplate onto valve.
14. Lubricate the threads on the adjusting screw (13) and thread into the spring housing (11). The adjusting screw should engage the hole on the spring guide (10) inside the spring housing (11). Turn the handle clockwise to place a light preload on the spring (9) to hold the parts in place.

Troubleshooting

If You Experience Erratic Control:

- Regulator may be oversized. Oversizing causes cycling and hunting, and reduces the rangeability of the valve – make certain that your valve has been correctly sized according to your application conditions.
- Valve seat may be defective - replace stem and/or body.
- Valve plug may not be moving freely – inspect the cylinder and spring housing.

Upstream Pressure Build-up or Inability to Maintain Regulated Pressure:

- Inspect for jamming between cylinder and spring housing.
- Diaphragm may have failed – replace if necessary.
- Piping may be blocked or undersized.

- Range spring may be set too high or may be broken – inspect and reset or replace as necessary.
- The valve may be undersized for required flow – make certain that the valve has been sized correctly.

Ordering Spare Parts

Use only genuine Steriflow Valve parts to keep your valve in good working order. So that we can supply the parts, which were designed for your valve, we must know exactly which product you are using. The only guarantee to getting the correct replacement parts is to provide your Steriflow Representative with the valve serial number. This number is located on the valve identification tag. If the serial number is not available, the parts needed for your valve might be determined using the following information: Model Number, Valve Body Size, Seat Material and Cv Rating, Spring Range and Set Point, Trim Material, Part Name - Number and Quantity.

NOTE: Any parts ordered without a valve serial number that are found to be incorrect are subject to up to a minimum 25% restock charge when returned.

Illustration and Parts List (3/4" - 3")

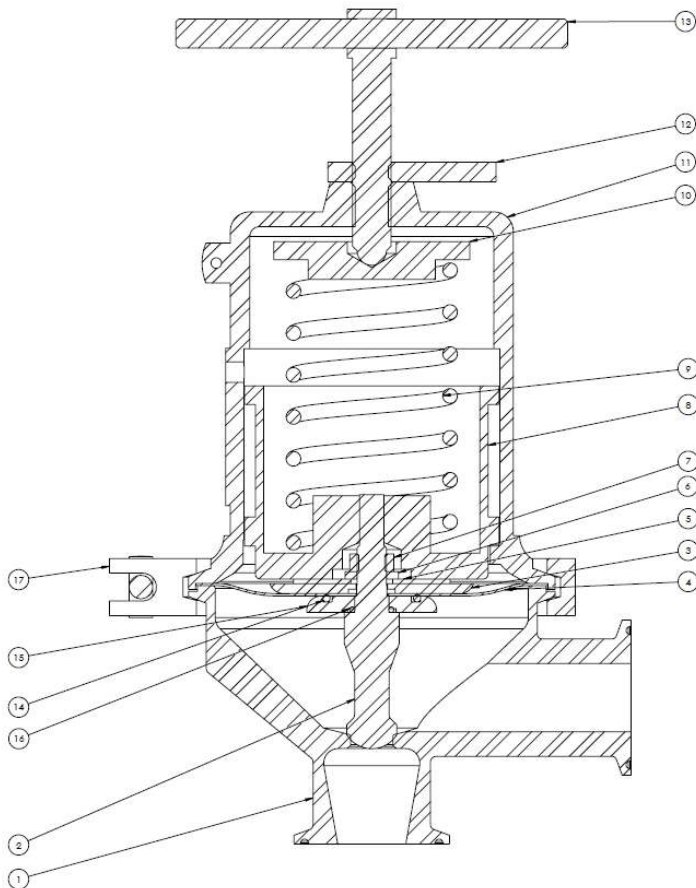

NO.	DESCRIPTION	QTY
1	BODY	1
2	STEM	1
3	UPPER DIAPHRAM PLATE	1
4	DIAPHRAGM	1
5	SPACER (WASHER)(AS NEEDED)	1
6	LOCKWASHER	1
7	HEX JAM NUT	1
8	CYLINDER	1
9	SPRING	1
10	SPRING GUIDE	1
11	SPRING HOUSING	1
12	THUMBLOCK	1
13	ADJUSTING SCREW ASS'Y	1
14	O-RING (JORLON DIA. ONLY)	1
15	LOWER DIAPHRAM PLATE	1
16	O-RING	1
17	4" TRI-CLAMP	1

