

SV7: TANDEM ACCESS VALVE

Manual or Pneumatically Actuated Forged body 2-way valves with access port

Tandem access valves (like ported valves) provide access to the interior of the body at the lowest possible cross section when the body is oriented at the optimal drain angle. However, a secondary valve is included so that you can control the flow for sampling, steam sterilization, purging or condensate drainage. Final configuration detail is confirmed with you prior to fabrication.

SPECIFICATIONS AND FEATURES*

Available Sizes:

- » Inlet and Outlet: 1/2" - 4" (DN15 - DN100)
- » Access Port: 1/2" - 1" (DN15 - DN25)

Connection Type:

- » Tri-clamp, Extended Tube End

Materials:

- » Standard: Forged EN10272:2000 Gr 1.4435 316L
- » Optional: Contact factory

Surface Finish:

- » Wetted Interior:
 - Standard:
 - ASME BPE SF1, 20 Ra μin (0,5 Ra μm)
 - ASME BPE SF5, 20 Ra μin (0,5 Ra μm) Electropolish
 - Optional:
 - ASME BPE SF4, 15 Ra μin (0,4 Ra μm) Electropolish. Better finish upon request
- » Exterior: as forged, Electropolished

* See page 5 & 6 for GENERAL FEATURES, GENERAL SPECIFICATIONS regarding features and specifications that apply to all valves

Please Contact Factory regarding dimensional drawings and how to order. All queries are welcome. All queries are welcome.



APPLICATIONS

Single Valve Wier valve with access port for sampling, SIP, purging or condensate drainage. Manual on/off or Air Actuated Control of Drug Process Additives, Drug Products and Clean Utilities

- » Upstream:
 - Bioreactor/Fermenter: For use on WFI, growth media, intermediate drug product, clean steam and clean utility fluids
 - Perfused Bioreactors: Retentate fluid
- » Downstream:
 - For use on WFI, buffers, solvent, intermediate and finished drug product, clean dry air and gas, clean steam, and clean utility fluids in the following production area
 - Separation
 - Filtration
 - Chromatography
 - Formulation
 - Fill Finish
- » Buffer and Media Prep:
 - For sampling, purging or draining of WFI, buffers, growth media or clean utility fluids

TANDEM INSTALLATION CONFIGURATIONS

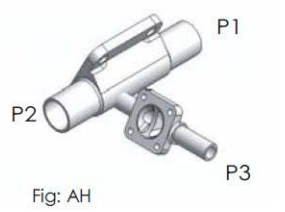
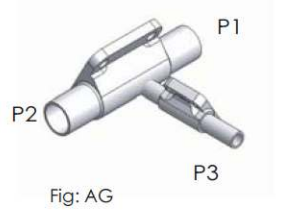
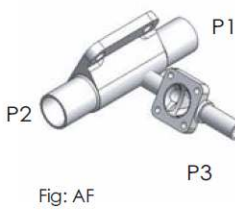
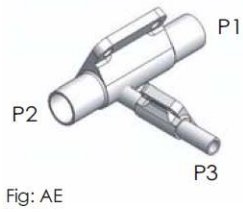
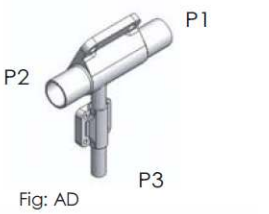
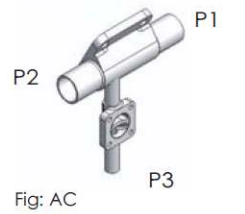
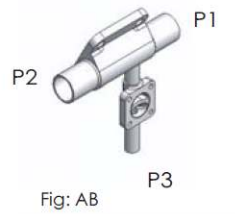
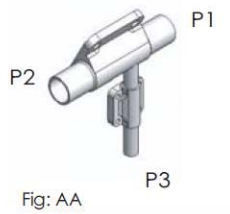
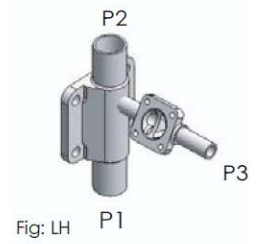
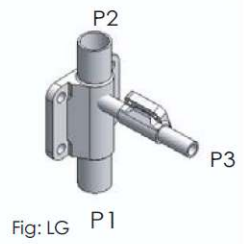
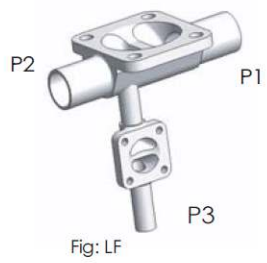
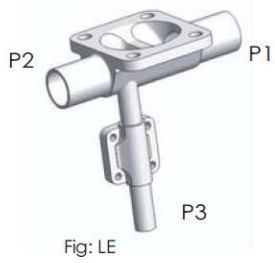
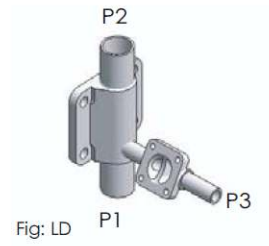
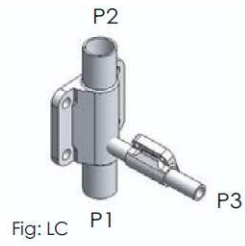
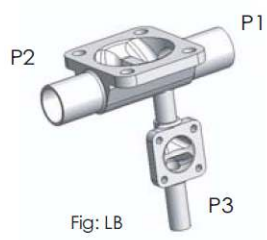
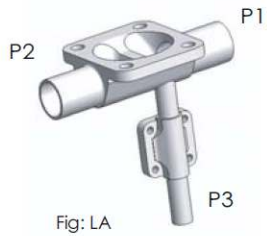

DIMENSIONS

Example drawings of some available configurations

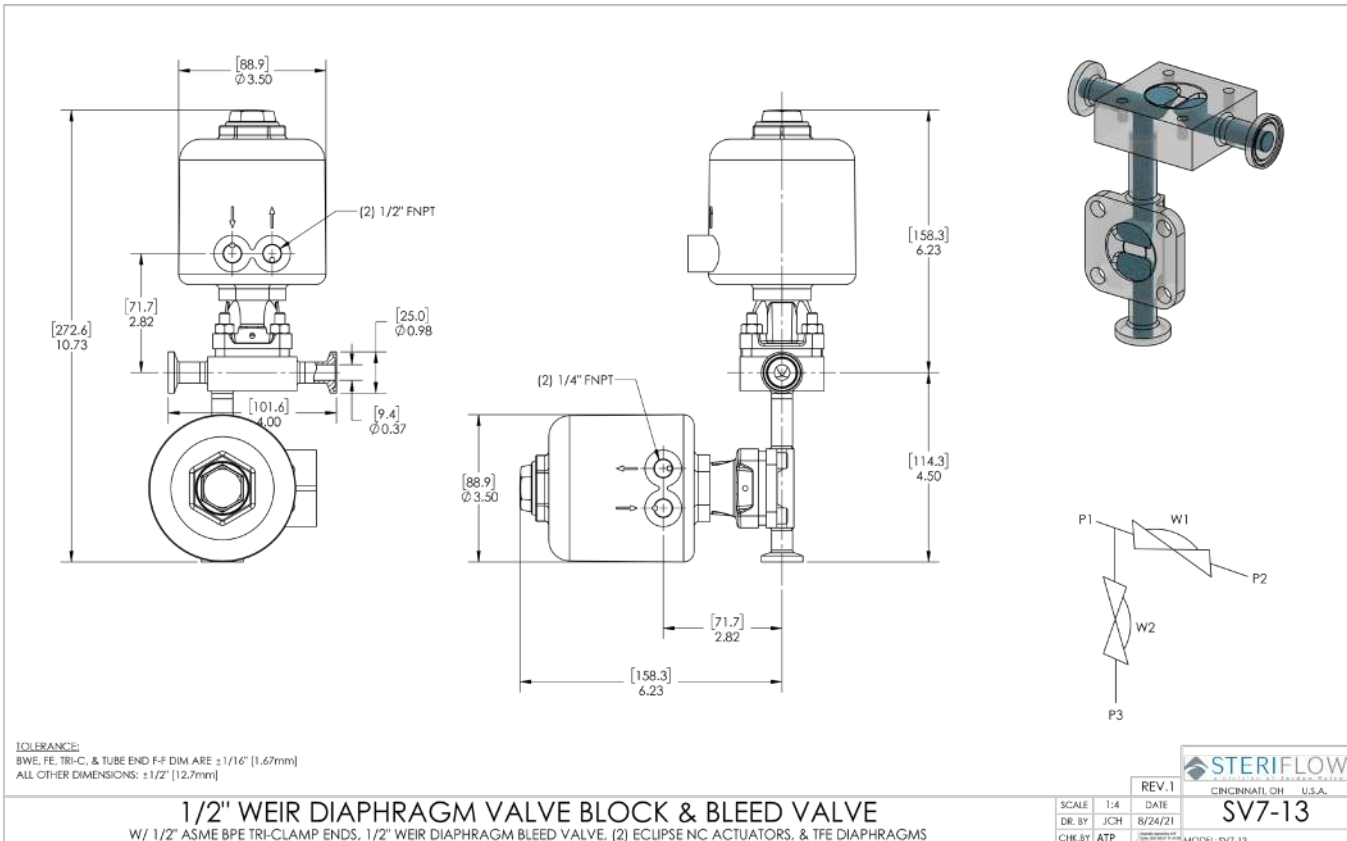
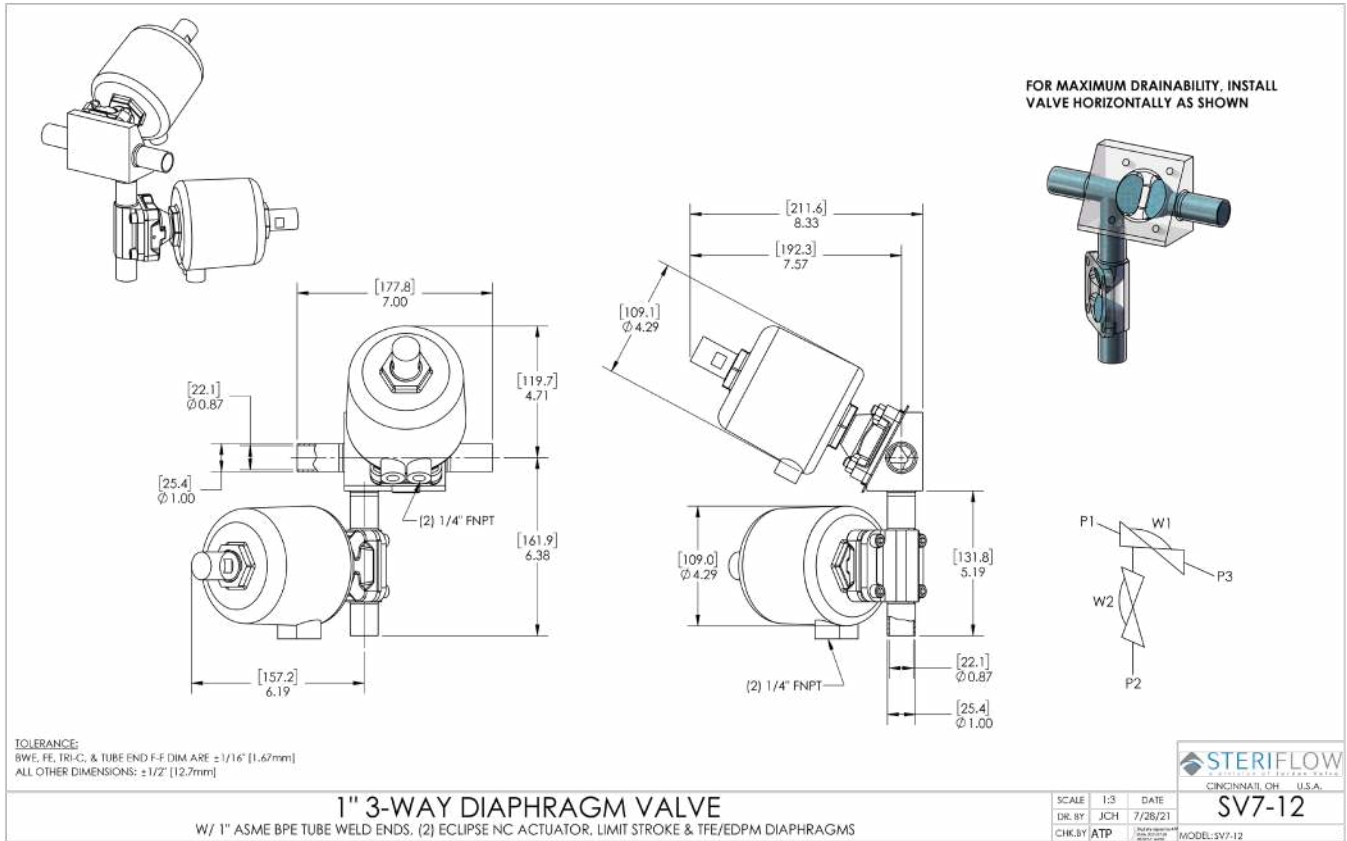

BONNET / ACTUATOR SPECIFICATIONS

Manual Bonnet Assembly:

- » Available for sizes: 1/2" - 4" (DN15 - DN100)
- » Closing Stop: adjustable
- » Bright visual position indicator
- » Options: contact factory for proximity switches, locking devices and stroke limiter

Bonnet Materials

- » Bonnet: electropolished Stainless Steel
- » Compressor: Stainless Steel
- » Insert: brass
- » Thrust Washer: PTFE
- » Compressor Pin: Stainless Steel
- » Indicator: Polyolefin
- » Stem: Stainless Steel
- » Handwheel: PPS (1/4" - 2") (DN8 - DN50); Stainless Steel (2-1/2" - 4") (DN65 - DN100)

Air Actuated Bonnets:

- » Available for sizes: 1/2" - 2" (DN15 - DN50) standard; 3" & 4" (DN80 & DN100) optional
- » Air Actuator Materials: Polyamide, Stainless Steel, Stainless Steel base standard for all configurations
- » Actuator Seal: Actuator springs and seals can be replaced without exposing process
- » Orientation: Swivel feature allows 360° orientation of air inlet
- » Air Connections: NPT Stainless Steel base standard for all configurations
- » Function: Change from Normally Open or Normally Closed by inverting the actuator housing
- » Control System Interface: Available with optional switch packages for on/off control or with positioners for flow control and modulation

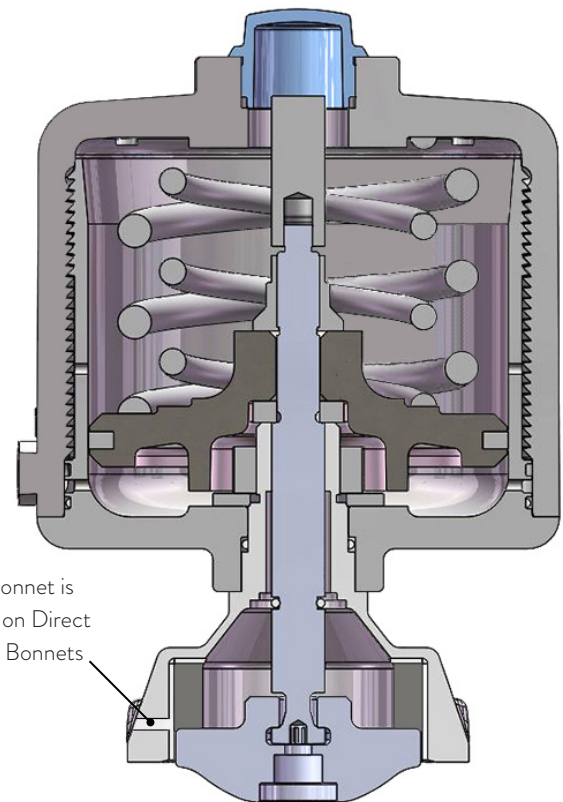
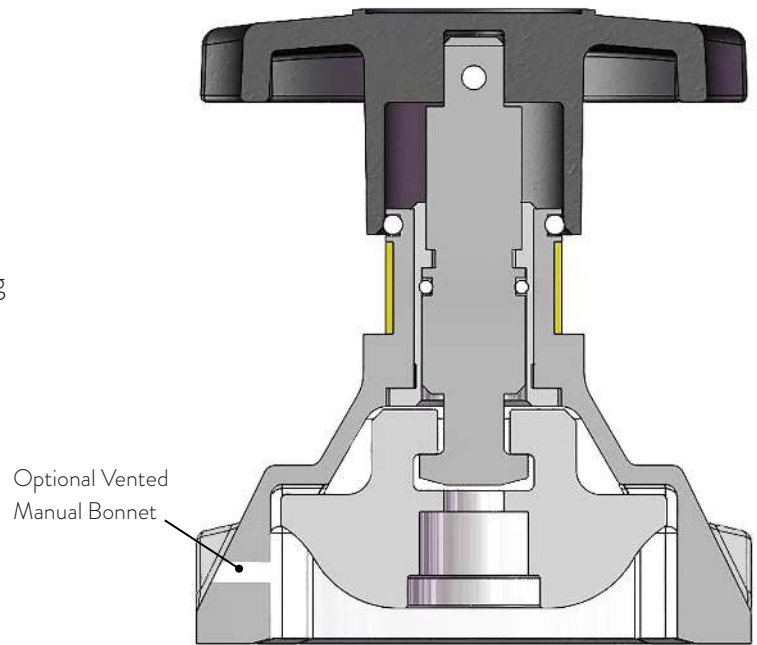

SANITARY DIAPHRAGM VALVES

Manual or Air Actuated Forged 2-way or Cast 2-way, Ported and Tandem valves. Barstock Zero Static T-Block, Point of Use T-Block, Divert Tank Bottom and Custom Block Body valves

FEATURES

- » Body & Trim Material: traceable ASME and DIN grade of 316L and Super-Austenitic Stainless Steel and Super Alloys readily available
- » Size Range: 1/4" - 4" (DN8 - DN100)
- » Manual or Air Actuated
- » Surface Finish:
 - Wetted Interior: ASME BBE SF5 20 Ra μ m (0.5 Ra μ m). Electropolish standard, SF4 and better finish available
 - Exterior: See individual model specifications
- » Diaphragm: All FDA, FDA/USP <88>, <87> Class VI, ADI-TSE Free
 - TFM/EPDM Backer
 - EPDM - Peroxide Cured

DOCUMENTATION





- » Steriflow Unicert; Certificate of Compliance for:
 - Material, including MTR's
 - Surface Finish
 - FDA/USP <88>, <87> Class VI
 - ADI/TSE Free cert available upon request
- » Each Unicert document lists the order's individual valve Serial/Suffix numbers and wetted component Heat numbers. MTR's for each Heat number follow on attached pages. The Serial numbers and Heat numbers are directly traceable to each individual valve
- » Valve Sizing information with quotation
- » Signed valve Leak Test report upon request

CERTIFICATION

- » CRN No.: 0C22893.5

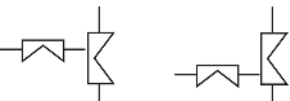
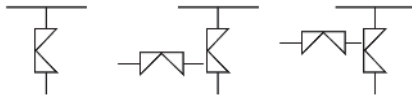
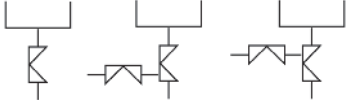
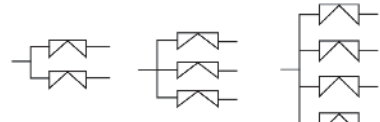

VALVE TYPE BY APPLICATION

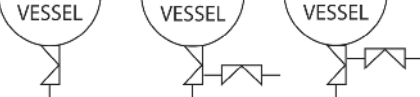
- » 2 - Ways 
- » Ported 
- » Tandem Access 
- » Zero Static T-Block 
- » Zero Static POU 
- » Divert Block 
- » Custom Blocks 
- » Tank Bottom 

GENERAL VALVE SPECIFICATIONS*

Line Size: 1/4" - 4" (DN8 - DN100)

End Connections: ASME BPE, DIN, ISO, Contact Factory

- » Tri-Clamp
- » Tube Weld End

Body Materials

- » Forgings: EN 10272:2000 GR 1.4435 316L standard
- » Bar Stock: ASME SA479 316L (UNS 31603) standard; EN 10272:2000 GR 1.4435, AL-6XN®, Hastelloy® C-22 and others readily available options

Diaphragm Material/Max Temperature: all diaphragms are FDA, USP <88> Class VI and <87> compliant and ADI-free

- » TFM/EPDM Backer / -14°F to 266°F (-26°C to 130°C) ≤300°F (150°C) at 50 psig (3,45 barg) max during SIP
- » EPDM Peroxide Cured / -14°F to 266°F (-26°C to 130°C) ≤300°F (150°C) at 50 psig (3,45 barg) max during SIP

Surface Finish: see individual valve specifications

Pressure at Maximum Temperature: 50 psig @ 300°F (3,45 barg @ 150°C)

Maximum Operating Pressure:

- » 1/4" - 1": 200 psi @ 100°F (13,8 bar @ 38°C)
- » 1-1/2" - 2": 175 psi @ 100°F (12,1 bar @ 38°C)
- » 2-1/2" - 4": 150 psi @ 100°F (10,3 bar @ 38°C)

Seat Leakage: ANSI FCI Class VI

FLOW COEFFICIENT CV (KV)

CONNECTION SIZE	VALVE DESCRIPTION	FLOW COEFFICIENT CV (KV)
1/4" - 1/2"	Compact valve/weir	1.16 (1,0)
1/2"	Any standard forged, barstock or cast body valve with catalog standard weir	5.2 (4,5)
3/4"		8.7 (7,52)
1"		13.9 (12,02)
1-1/2"		34.8 (30,1)
2"		59.7 (51,6)
3"		185 (160)
4"		272 (235)

BONNET/ACTUATOR SPECIFICATIONS*

Manual Bonnet Assembly:

- » Available for valve sizes: 1/2" - 4" (DN15 - DN100)
- » Closing Stop: Adjustable
- » Bright visual position indicator
- » Options: Contact factory for proximity switches, locking devices and stroke limiter

Bonnet Materials

- » Bonnet: Electropolished Stainless Steel
- » Compressor: Stainless Steel
- » Insert: Brass
- » Thrust Washer: PTFE
- » Compressor Pin: Stainless Steel
- » Indicator: Polyolefin
- » Bushing: Brass
- » Stem: Stainless Steel
- » Handwheel: PPS (1/4" - 2"); Stainless Steel (2-1/2" - 4")

Air Actuated Bonnets:

- » Available for sizes: 1/2" - 2" (DN15 - DN50) standard; 3" & 4" (DN80 & DN100) optional
- » Air Actuator Materials: Polyamide, Stainless Steel, Stainless Steel base standard for all configurations
- » Actuator Seal: Actuator springs and seals can be replaced without exposing process
- » Orientation: Swivel feature allows 360° orientation of air inlet
- » Air Connections: NPT Stainless Steel base standard for all configurations
- » Function: Change from Normally Open or Normally Closed by inverting the actuator housing
- » Control System Interface: Available with optional switch packages for on/off control or with positioners for flow control and modulation

* Most valves meet all of these general features and specifications. However, sizes may vary depending upon product selected. See individual product page for specific details about each model.