



STERIFLOW
a division of Jordan Valve

3170 Wasson Road • Cincinnati, OH 45209 USA
Phone 513-533-5600 • Fax 513-871-0105
steriflow@richardsind.com • www.steriflowvalve.com

I & M JSRHULP Series

Installation & Maintenance Instructions for JSRHULP Series Sanitary Valves

Warning: Warning: Steriflow Sanitary Regulators must only be used, installed and repaired in accordance with these Installation & Maintenance Instructions. Observe all applicable public and company codes and regulations. In the event of leakage or other malfunction, call a qualified service person; continued operation may cause system failure or a general hazard. Before servicing any valve, disconnect, shut off, or bypass all pressurized fluid. Before disassembling a valve, be sure to release all spring tension.

Please read these instructions carefully!

Your Steriflow/Jordan product will provide you with long, trouble-free service if it is correctly installed and maintained. Spending a few minutes now reading these instructions can save hours of trouble and downtime later. When making repairs, use only genuine Steriflow Valve parts, available for immediate shipment from the factory.

Ideal Installation

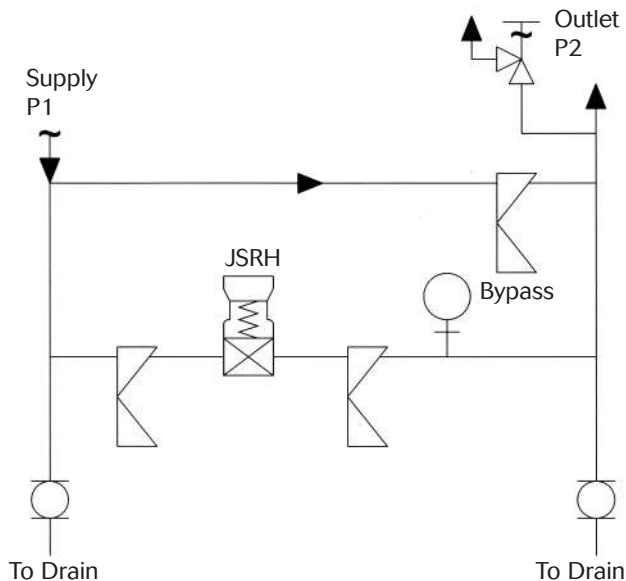

Preferred Installation

Caution! Installation of adequate overpressure protection is recommended to protect the regulator from overpressure and all downstream equipment from damage in the event of regulator failure.

1. An inlet block valve should always be installed.
2. If service application is continuous such that shut-down is not readily accomplished, it is recommended that an inlet block valve, outlet block valve, and a manual bypass valve be installed. Sanitary diaphragm or ball valves are usually recommended.
3. A sanitary outlet pressure gauge should be located

approximately ten pipe diameters downstream, and within sight. If you have ordered your JSRHULP with the outlet gauge option on the valve, please note that the outlet pressure as registered on the gauge may be slightly higher than a gauge located x diameters downstream, with the difference typically no more than 0.5 psig.

4. All installations should include a downstream relief device if the inlet pressure could exceed the pressure rating of any downstream equipment or the maximum outlet rating of the unit.
5. Flow Direction: install so that the flow direction matches the inlet/outlet marking on the main regulator body (1).
6. For best performance, install in well drained horizontal pipe
7. Regulator may be rotated around the pipe axis 360°. Recommended position is with the closing cap (23) vertical upwards.
8. Regulators are not to be buried underground.
9. For insulated piping systems, recommendation is to not insulate the regulator.

Principles of Operation

1. Movement occurs as pressure variations register on the diaphragm (10). The registering pressure is the outlet, P2, or downstream pressure. The range spring (20) opposes diaphragm (10) movement. As outlet pressure decreases, the range spring (20) pushed the diaphragm (10) down, opening the port. As outlet pressure increases, the diaphragm (10) pushes up and the port opening closes.
2. A complete diaphragm (10) failure will cause the regulator to fail open.
NOTE: The outlet pressure for this valve should not exceed 25 psig.

Start Up

Caution! Don't exceed the maximum rated pressure of the regulator if installed for a hydrostatic test. Isolate the unit if the test is above the valve rating. (Valve rating is 150 psi @ 100°F).

1. Start with the block valves closed. A bypass valve may be used to maintain outlet pressure in the downstream system without changing the following steps.
2. Relax the range spring (20) by turning the adjusting screw (21) counter-clockwise (CCW) until there is no noticeable spring tension.
3. If it is a "hot" piping system, and equipped with a bypass valve, slowly open the bypass valve to pre-heat the system piping and to allow slow expansion off the piping. Closely monitor outlet (downstream) pressure via gauge to ensure no over-pressurizing occurs. Note: if no bypass valve is installed, extra caution should be used in starting up a cold system; i.e. do everything slowly.
4. Crack open the outlet (downstream) block valve.
5. Slowly open the inlet (upstream) block valve, observing the outlet (downstream) pressure gauge. Determine if the regulator is flowing. If not, slowly rotate the regulator adjusting screw (21) clockwise (CW) until flow begins.
6. Continue to slowly open the inlet (upstream) block valve until fully open.
7. Continue to slowly open the outlet (downstream) block valve, especially when the downstream piping isn't pressurized. If the outlet (downstream) pressure exceeds the desired pressure, close the block valve and go to Step 2, then return to Step 4.
8. When flow is established steady enough that the outlet (downstream) block is fully open, begin to slowly close the bypass valve, if installed.
9. Develop system flow to a level near its expected normal rate, and reset the regulator set point by turning the adjusting screw (21) CW to increase outlet pressure, or CCW to reduce outlet pressure.
10. Reduce system flow to a minimum level and observe set point. Outlet pressure will rise from the set point of Step 9.

Shutdown

1. On systems with a bypass valve, and where system pressure is to be maintained as the regulator is shut-down, slowly open the bypass valve while closing the inlet (upstream) block valve. (When on bypass, the system pressure must be constantly observed and manually regulated.) Close the outlet (downstream) block valve. CAUTION! Do not walk away and leave a bypassed regulator unattended.
2. If the regulator and system are up to both be shut-down, slowly close the inlet (upstream) block valve. Close the outlet (downstream) valve only if regulator removal is required.

Maintenance

Warning! System Under Pressure. Prior to performing

any maintenance, isolate the regulator from the system and relieve all pressure. Failure to do so could result in personal injury.

A. General

1. Maintenance procedures hereinafter are based upon removal of the regulator unit from the pipeline where installed.
2. Owner should refer to owner's procedures for removal, handling, cleaning and disposal of non-reusable parts, i.e. gaskets, etc.
3. Refer to assembly with bill of materials for basic regulator and Figure 1 for trim subassembly.

B. Trim Replacement

Note: Complete trim and diaphragm replacement as well as wet side cleaning can be done with the valve still installed, however removal is recommended. Additionally, please note the cautions above. Make sure all upstream and downstream valves are closed and all pressure is relieved prior to beginning work.

1. Remove closing cap (23).
2. Mark position of adjusting screw (21) where it meets jam nut (26).
3. Slightly loosen the jam nut (26) and remove the adjusting screw (21), leaving the jam nut in position.
4. Remove actuator case bolts, lock washers and nuts (12,13,14). Remove upper actuator case assembly (25,22).
5. Remove diaphragm assembly (8,9,10,15,17,18,28) and set aside on a clean surface.
6. Holding the body (1) in a smooth jawed vise.
7. Remove the diffuser (5) first and then the plug sub-assembly (2,6,7). Then remove the return spring (3).
8. Clean all parts to be reused according to owner's procedures.
9. Inspect all parts for damage and replace if necessary. Note: Use only parts manufactured and supplied by Steriflow Valve for these parts.



Figure 1: Plug Sub-Assembly

10. Place new diffuser gasket (6) into the bottom of the

threaded end of the diffuser (5).

11. Place the return spring (3) into the body (1). Next, place the plug sub-assembly (2,6,7) into the body (1) cavity, engaged into the return spring (3).
12. Screw the difusser (5) into the body (1) cavity center hole.
13. Reassemble the rest of the valve by place diaphragm assembly (8,9,10,15,17,18,28) onto the plug assembly. Place the range spring (20) and upper spring guide (19) back onto the lower spring guide (18).
14. Place the upper actuator case assembly (25,22) onto the lower case and tighten the actuator case bolts, lock washers and nuts (12,13,14).
15. Screw in the adjusting screw (21) and jam nut (26).
16. Place the closing cap (23) back on the spring housing (22)
17. Bench test unit for suitable operation. Note: Regulators are not tight shutoff devices. Even if pressure builds up beyond set up, a regulator may or may not develop bubble tight shutoff.
18. Pressurize with air and spray liquid leak detector around the body (1) and spring housing (22) to test for leakage. Ensure that an outlet pressure is maintained during this leak test of at least mid-range spring level: i.e. 4-18" WC (0.14-0.65 psig) range spring, 10"WC (0.36 psig) test pressure minimum.

C. Diaphragm Replacement

Caution! To prevent damage to body, use soft jaws when placing when placing the body in a vise.

1. Remove closing cap (23).
2. Mark position of adjusting screw (21) where it meets jam nut (26).
3. Slightly loosen the jam nut (26) and remove the adjusting screw (21), leaving the jam nut in position.
4. Remove actuator case bolts, lock washers and nuts (12,13,14). Remove upper actuator case assembly (25,22).
5. Remove the upper spring guide (19) and range spring (20). Remove and discard the actuator case gasket (11).
6. Remove the diaphragm retaining nut (28), lock washer (17), lower spring guide (18), diaphragm plate gaskets (15), diaphragm (10) and diaphragm plates (9) from the diaphragm center bolt (8).
7. Inspect all parts to be reused and replace if necessary. Note: Use only parts manufactured and supplied by Steriflow Valve for these parts.
8. Assemble in reverse order using new replacement parts. Use cross section view for reference.
9. If valve was removed from system, unit can be bench tested for suitable operation. Note: Regulators are not tight shutoff devices. Even if pressure builds up beyond set point, a regulator may or may not develop bubble tight shutoff.

10. Pressurize with air and spray liquid leak detector around the main body (2), upper diaphragm casing (25), and spring housing (22) to test for leakage. Ensure that an outlet pressure is maintained during this leak test of at least mid-range spring level: i.e. 4-18" WC (0.14-0.65 psig) range spring, 10"WC (0.36 psig) test pressure minimum.

Troubleshooting

1. Erratic Operation; Chattering

- A. Oversize regulator; inadequate rangeability
 1. Check actuator flow conditions, re-size regulator for minimum and maximum flow.
 2. Increase flow rate.
 3. Decrease regulator pressure drop; decrease inlet pressure by placing a throttling orifice in inlet piping.
 4. Install next step higher range spring. Before replacing regulator, contact factory
- B. Worn poppet; inadequate guiding
 1. Replace trim (possible body replacement)
- C. Weakened/broken return spring.
 1. Determine if corrosion is causing. Replace return spring.

2. Regulator can't pass sufficient flow

- A. Regulator not closing tightly
 1. Inspect the seat of the plug sub-assembly, replace if worn.
- B. Downstream blockage
 1. Check system; isolate (block flow at regulator inlet - not outlet.
 2. Relocate regulator if necessary
- C. No pressure relief protection
 1. Install safety relief valve, or rupture disc.
- D. Restricted diaphragm movement
 1. Ensure no moisture in spring chamber at temperature below free point.

Cross Section View

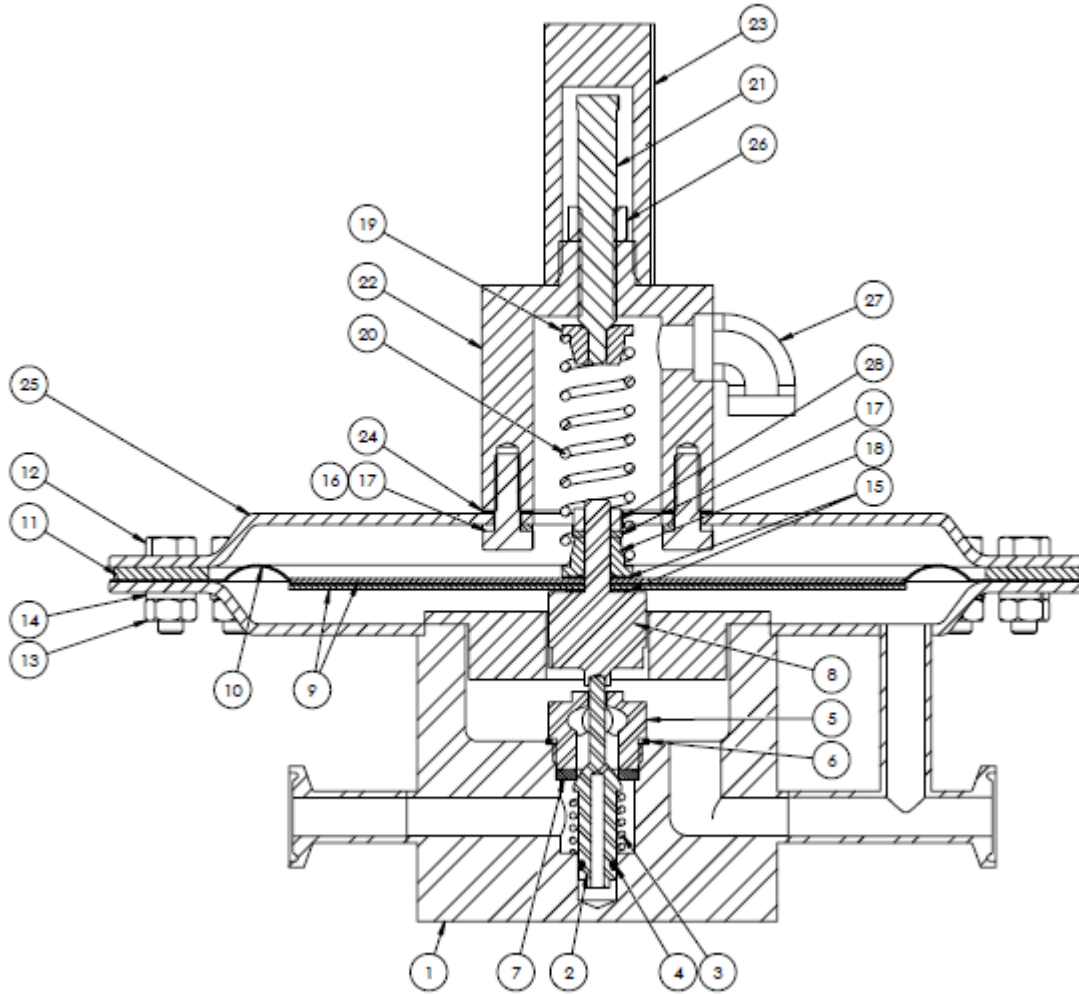

Item	Description	Qty.	Item	Description	Qty.
1	BODY ASSEMBLY	1	15	DIAPHRAGM PLATE GASKET	2
2	PLUG	1	16	1/4-20 X 3/4" HHCS FOR SPRING HOUSING	4
3	RETURN SPRING	1	17	1/4" LOCKWASHER FOR SPRING HOUSING	5
4	O-RING	1	18	LOWER SPRING GUIDE	1
5	DIFFUSER	1	19	UPPER SPRING GUIDE	1
6	DIFFUSER GASKET	1	20	RANGE SPRING 2-18" WC	1
7	SOFT SEAT	1	21	ADJUSTING SCREW	1
8	DIAPHRAGM CENTER BOLT	1	22	SPRING HOUSING	1
9	DIAPHRAGM SUPPORT PLATE	2	23	CLOSING CAP	1
10	DIAPHRAGM	1	24	SMALL GASKET FOR ACTUATOR CASE	1
11	ACTUATOR CASE GASKET, LARGE	1	25	UPPER ACTUATOR CASE	1
12	1/4-20 X 3/4" HHCS F/ DIAPHRAGM CASE	16	26	JAM NUT FOR ADJUSTING SCREW	1
13	1/4-20 HEX NUT FOR DIAPHRAGM CASE	16	27	ELBOW 1/4" FNPT X 1/4" FNPT	1
14	1/4" LOCKWASHER FOR DIAPHRAGM CASE	16	28	1/4-20 HEX NUT	1