

SG Series

In-Line Sight Glasses

The in-line sight glasses offered by Steriflow are suitable for a wide range of ASME BPE applications in high purity tubing systems typically found in the pharmaceutical or bio-pharmaceutical industry.

The double window design ensures optimum viewing area and eliminates the need for a back light. The bore of the glass and end fittings match that of the corresponding tubing size, preventing the possibility of fluid retention, even when units are installed horizontally.

The SG Series sight glasses combine 316L stainless steel end connections with a toughened borosilicate viewing glass making them suitable for both clean-in-place (CIP) and sterilization-in-place (SIP) operations. Standard units are available in 1/2" to 4" sizes with Tri-clamp® compatible connections. Alternative sizes and connection types can also be supplied.

Where there is a risk of accidental damage to the viewing glass, a Polycarbonate shield or perforated viewing tube can be supplied.

FEATURES

- Full bore flow path
- Large viewing area
- Compact design
- Suitable for CIP and SIP
- Better than SF1, 16 Ra µin mechanical polish, (0,4 µm Ra)
- Electropolish optional

STANDARDS

- Where applicable, all sight glass models comply with ASME BPE criteria
- All sight glass models are CE compliant under the SEP category of the PED directive
- All seal materials are FDA and USP Class VI compliant

CLEANING & PACKAGING

- All sight glasses are cleaned after manufacture, capped, sealed in a polythene bag and individually boxed



DOCUMENTATION

The following documentation is shipped with each order:

- Steriflow Unicert
 - Traceable Material Heat Number for body and ferrels
 - Certificate of Compliance to FDA and USP Class VI
 - Certificate of Surface Finish
- Final Test Reports and Certificate of Origin available upon request at time of order



Steriflow by Jordan Valve

3170 Wasson Road • Cincinnati, OH 45209
513.533.5600 • 800.543.7311 • 513.871.0105 (f)
steriflow@richardsind.com • www.steriflowvalve.com

SPECIFICATIONS

Sizes: 1/2", 3/4", 1", 1-1/2", 2", 2-1/2", 3", 4"

End Connections

- Tri-clamp® compatible

Materials of Construction

- Body – 316L Stainless Steel
- End fitting – 316L Stainless Steel
- Glass – Borosilicate
- Seals – EPDM, Viton, Silicone or FEP-Silicone (all FDA and USP VI compliant)

Surface Finish

- Internal – better than SF1; 16 Ra µin (0,4 µm) mechanical finish, Electropolish optional
- External – 32 Ra µin (0,8 µm) mechanical finish, electropolish optional

Operating Conditions

- Maximum operating pressure – 145 psig (10 barg)
- Maximum allowable temperature with EPDM seals – 175°F (135°C)
- Maximum allowable temperature with FEP-Silicone, Viton or Silicone seals – 392°F (200°C)

Options

- DIN, ISO & SMS sizes available upon request
- Electropolished finishes
- Perforated viewing tube
- Alternative lengths / weld end connections

Certifications

- Steriflow Unicert
 - Traceable Material Heat Number for body and ferrels
 - Certificate of Compliance to FDA and USP Class VI

Certificate of Surface Finish

- Final Test Reports and Certificate of Origin available upon request at time of order

ORDERING SCHEMATIC

Model	Size	Seal	Shield	Finish

Model	
SG	Sight Glass

Size	
050	1/2" ASME BPE Tri-Clamp®
075	3/4" ASME BPE Tri-Clamp®
100	1" ASME BPE Tri-Clamp®
150	1-1/2" ASME BPE Tri-Clamp®
200	2" ASME BPE Tri-Clamp®
250	2-1/2" ASME BPE Tri-Clamp®
300	3" ASME BPE Tri-Clamp®
400	4" ASME BPE Tri-Clamp®

Seal	
EP	EPDM, FDA, USP Class VI
VI	Viton, FDA, USP Class VI
SI	Silicone, FDA, USP Class VI
FI	FEP-Silicon for USP Class VI

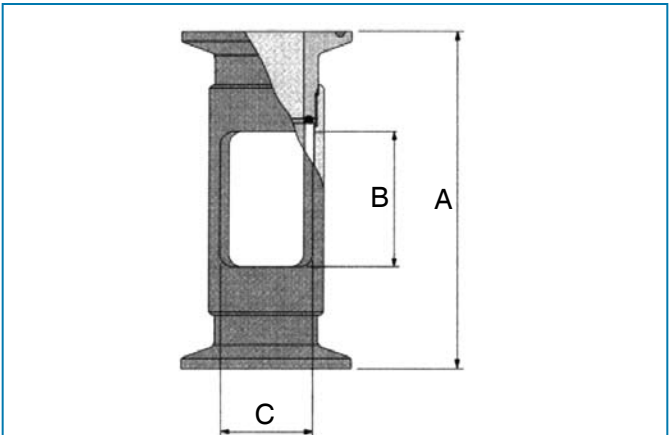

Valve Size	A	B	Viewing Area C°
1/2", 3/4"	3.54 (90mm)	1.57 (40mm)	120°
1" – 4"	3.94(100mm)	1.57 (40mm)	120°

Shield	
00	None
KS	Polycarbonate outer shield

Finish	
00	Standard Mechanical Polish
EP	Electro-Polish



Steriflow, a division of Jordan Valve

3170 Wasson Road • Cincinnati, OH 45209
 513.533.5600 • 800.543.7311 • 513.871.0105 (f)
 steriflow@richardsind.com • www.steriflowvalve.com

Steriflow Valve reserves the right to make revisions to its product, specifications, literature and related information without notice. Please visit our website at www.steriflowvalve.com for the latest information on our products.