

# Mark 968 Series

Sanitary Gas Regulators sizes 3/4" through 2" for pharmaceutical, food & beverage tank blanketing and gas motive force applications

The Mark 968 Sanitary Gas Regulator is the ideal valve for low pressure gas regulation in pharmaceutical and food & beverage applications. The self-contained low pressure gas regulator is for use on tank blanketing and other low pressure air and gas applications.

The Mark 968 is normally open. Increases in the outlet pressure are sensed through the aspirator causing the large elastomer diaphragm to rise, which moves the plug toward the seat. As outlet pressure decreases, the diaphragm moves down and moves the plug away from the seat to increase flow. The lever, which connects the stem to the diaphragm, amplifies diaphragm forces for tighter shutoff (only available on sizes 3/4" and 1").

The large diaphragm and lever actuation allows the Mark 968 to act with higher sensitivity compared to smaller diaphragm pressure regulators. High sensitivity is important, as the Mark 968 often works with very low pressure (down to 1" w.c. or 2,5 mbar). This special actuation improves the accuracy and shutoff of the valve - two important benefits in this style of regulator. Together, the SST construction, FDA-approved seals and the tri-clamp connections make this valve well suited for sterile gas applications and environments.

## FEATURES

- Inlet pressures up to 150 psi (10 bar)
- Robust design — emergency outlet pressure may reach 100% of inlet pressure without damaging valve
- 360° body orientation — valve can be installed in any position, and can be easily repositioned while in-line
- Easy maintenance — seat and plug can be inspected without removing body from the line
- Completely self-operated — no external power source required
- Tight shutoff — soft elastomer plug provides ANSI Class VI shutoff
- 316/316L SST body/trim and tri-clamp, quick disconnect clamp connection
- FDA-approved seals and diaphragms
- Optional electropolishing available



## SPECIFICATIONS

**Line Sizes:** 3/4" (DN20) & 1" (DN25)

### End Connections

- Clamped — ISO/DIN or Tri Clamp
- Flanged — 150#, 300#, PN25/40 & sterile flanges

### Materials

- Body & Housing: SA352/CF8M Stainless Steel
- Seat: 316/316L Stainless Steel
- Plug: Stainless Steel and FDA-approved Viton
- Diaphragm: Viton (FDA)
- Aspirator Tube: FDA USP Class VI Teflon

**Service:** Air or gas

**Shutoff:** ANSI Class VI

**Temperature Range:** -20°F (-29°C) to 200°F (93°C)

**Maximum Inlet Pressure:** 150 psi (10 bar)

### Reduced Pressure Control Range:

- 1.0 to 2.5 inches w.c. (2,5 to 6,2 mbar)
- 2.0 to 5.5 inches w.c. (5,0 to 13,7 mbar)
- 4.0 to 10.0 inches w.c. (10,0 to 24,9 mbar)
- 5.0 to 30.0 inches w.c. (12,4 to 74,7 mbar)
- 0.5 to 1.75 psig (0,03 to 0,12 bar)
- 1.0 to 3.5 psig (0,07 to 0,24 bar)

**Orifice Sizes (Interchangeable):** 1/8" (3mm), 3/16" (5mm), 1/4" (6mm), 5/16" (8mm), 3/8" (10mm), 7/16" (11mm), 1/2" (13mm), 9/16" (14mm)

### 3/4" N<sub>2</sub> FLOW CAPACITY: SCFH

To select the orifice size for your valve you need to know P1 (inlet pressure), P2 (outlet pressure set point), and maximum flow in SCFH.

1. Select the row that best represents your outlet Set Pressure (P2)
2. Select the sub-row that is representative of your Inlet Pressure (P1)
3. Find the Flow rate in that sub-row that encompasses your maximum flow. Look at the orifice column heading to determine your specific orifice size.

Set Pressure	Inlet (psi)	Orifice Size								
		1/8"	3/16"	1/4"	5/16"	3/8"	7/16"	1/2"	9/16"	
2" H2O (1-2.5" H2O) 1" H2O Droop 2" H2O Boost*	5	201	374	430	261	477	888	1043	1169	
	10	213	402	456	580	506	784	943		
	20	222	392	475	619	361				
	40	299	465	639	764					
	60	665	897	1161			Flow in this area is outside the operating parameters of the valve			
	80	816	873	1139						
	100	598	640							
	150	770	825							
3" H2O (2-5" H2O) 1" H2O Droop 2" H2O Boost*	5	239	373	503	560	613	886	1163	1195	
	10	231	402	566	580	591	783	977		
	20	211	392	570	619	295				
	40	277	465	649	764					
	60	597	897	1194			Flow in this area is outside the operating parameters of the valve			
	80	753	873	976						
	100	675	776							
	150	880	825							
7" H2O (4-10" H2O) 1" H2O Droop 2" H2O Boost*	5	220	295	372	409	441	619	799	661	
	10	277	427	578	527	476	732	982		
	20	258	462	661	893	1118	1154			
	35	276	592	897	967	1035	1294			
	75	525	980	1426				Flow in this area is outside the operating parameters of the valve		
	90	727	1364							
	100	813	1503							
	150	1040	1926							
28" H2O (5-30" H2O) 5-1/2" H2O Droop	5	302	454	604	722	839	941	1040	1074	
	10	337	533	723	981	1239	1378	1514		
	30	283	816	1335	1666	1982	2154			
	45	617	1373	2058	2487					
	60	817	1866	2906	2899			Flow in this area is outside the operating parameters of the valve		
	75	820	1812							
	100	840	1867							
	150	1089	2421							
1.25 psi (0.5 - 1.75 psi) 0.2 psi Droop	5	180	272	439	395	526	465	658	921	
	10	235	333	522	535	783	665	913	848	
	30	279	469	824	785	1014	1141			
	45	354	561	886	856	1033				
	60	418	669	1003	937	1087		Flow in this area is outside the operating parameters of the valve		
	75	427	762	1152						
	100	543	949	1402						
	150	715	1266	1816						
3 psi (1 - 3.5 psi) 0.3 psi Droop	5	145	217	289	315	338	371	402	675	
	10	209	312	418	502	592	625	661	731	
	30	226	468	701	783	859	1136			
	45	354	561	812	856	856				
	60	415	669	922	937	945		Flow in this area is outside the operating parameters of the valve		
	75	427	762	1059						
	100	503	949	1408						
	150	660	1266	1816						

\* Boost refers to a small rise in outlet pressure set point that can occur, and is characteristic of, this type of regulator when flow nears the valve's maximum capacity. To understand this phenomenon and to determine your maximum flow requirements, see API 2000

### 3/4" N<sub>2</sub> FLOW CAPACITY: NM<sup>3</sup>/H

**To select the orifice size for your valve you need to know P1 (inlet pressure), P2 (outlet pressure set point), and maximum flow in NM<sup>3</sup>/H.**

1. Select the row that best represents your outlet Set Pressure (P2)
2. Select the sub-row that is representative of your Inlet Pressure (P1)
3. Find the Flow rate in that sub-row that encompasses your maximum flow. Look at the orifice column heading to determine your specific orifice size.

Set Pressure	Inlet (bar)	Orifice Size								
		1/8"	3/16"	1/4"	5/16"	3/8"	7/16"	1/2"	9/16"	
2" H2O (1-2.5" H2O)	0.345	5.7	10.6	12.2	7.4	13.5	25.1	29.5	33.1	
	0.689	6.0	11.4	12.9	16.4	14.3	22.2	26.7		
	1.38	6.3	11.1	13.4	17.5	10.2				
	2.76	8.5	13.2	18.1	21.6					
	4.14	18.8	25.4	32.9		Flow in this area is outside the operating parameters of the valve				
	5.52	23.1	24.7	32.2						
	6.89	16.9	18.1							
1" H2O Droop 2" H2O Boost*	10.3	21.8	23.3							
	0.345	6.8	10.6	14.2	15.8	17.3	25.1	32.9	33.8	
	0.689	6.5	11.4	16.0	16.4	16.7	22.2	27.6		
	1.38	6.0	11.1	16.1	17.5	8.3				
	2.76	7.8	13.2	18.4	21.6					
	4.14	16.9	25.4	33.8		Flow in this area is outside the operating parameters of the valve				
	5.52	21.3	24.7	27.6						
3" H2O (2-5" H2O)	6.89	19.1	22.0							
	10.3	24.9	23.3							
	0.345	6.2	8.3	10.5	11.6	12.5	17.5	22.6	18.7	
	0.689	7.8	12.1	16.4	14.9	13.5	20.7	27.8		
	1.38	7.3	13.1	18.7	25.3	31.6	32.7			
	2.41	7.8	16.8	25.4	27.4	29.3	36.6			
	5.17	14.9	27.7	40.4		Flow in this area is outside the operating parameters of the valve				
7" H2O (4-10" H2O)	6.21	20.6	38.6							
	6.89	23.0	42.5							
	10.3	29.4	54.5							
	0.345	8.5	12.8	17.1	20.4	23.7	26.6	29.4	30.4	
	0.689	9.5	15.1	20.5	27.8	35.1	39.0	42.8		
	2.07	8.0	23.1	37.8	47.1	56.1	61.0			
	3.10	17.5	38.9	58.2	70.4					
5-1/2" H2O Droop	4.14	23.1	52.8	82.2	82.0		Flow in this area is outside the operating parameters of the valve			
	5.17	23.2	51.3							
	6.89	23.7	52.8							
	10.3	30.8	68.5							
	0.345	5.1	7.7	12.4	11.2	14.9	13.2	18.6	26.1	
	0.689	6.7	9.4	14.8	15.1	22.2	18.8	25.8	24.0	
	2.07	7.9	13.3	23.3	22.2	28.7	32.3			
0,09 bar (0.03 - 0,12 bar)	3.10	10.0	15.9	25.1	24.2	29.2				
	4.14	11.8	18.9	28.4	26.5	30.8		Flow in this area is outside the operating parameters of the valve		
	5.17	12.1	21.5	32.6						
	6.89	15.4	26.9	39.7						
	10.3	20.2	35.8	51.4						
	0.345	4.1	6.1	8.2	8.9	9.5	10.5	11.4	19.1	
	0.689	5.9	8.8	11.8	14.2	16.8	17.7	18.7	20.7	
0,21 bar (0,07 - 0,24 bar)	2.07	6.4	13.2	19.8	22.2	24.3	32.1			
	3.10	10.0	15.9	23.0	24.2	24.2				
	4.14	11.7	18.9	26.1	26.5	26.7		Flow in this area is outside the operating parameters of the valve		
	5.17	12.1	21.5	30.0						
	6.89	14.2	26.9	39.8						
	10.3	18.7	35.8	51.4						

\* Boost refers to a small rise in outlet pressure set point that can occur, and is characteristic of, this type of regulator when flow nears the valve's maximum capacity. To understand this phenomenon and to determine your maximum flow requirements, see API 2000

MARK 968 SANITARY GAS REGULATOR

1" N<sub>2</sub> FLOW CAPACITY: SCFH

To select the orifice size for your valve you need to know P1 (inlet pressure), P2 (outlet pressure set point), and maximum flow in SCFH.

1. Select the row that best represents your outlet Set Pressure (P2)
2. Select the sub-row that is representative of your Inlet Pressure (P1)
3. Find the Flow rate in that sub-row that encompasses your maximum flow. Look at the orifice column heading to determine your specific orifice size.

Set Pressure	Inlet (psi)	Orifice Size								
		1/8"	3/16"	1/4"	5/16"	3/8"	7/16"	1/2"	9/16"	
2" H2O (1-2.5" H2O) 1" H2O Droop 2" H2O Boost*	5	226	420	483	630	536	998	1172	1313	
	10	328	618	702	893	779	1206	1450		
	20	493	872	1055	1376	803				
	40	786	1224	1681	2010					
	60	1073	1447	1872			Flow in this area is outside the operating parameters of the valve			
	80	1360	1455	1898						
	100	1648	1763							
3" H2O (2-5" H2O) 1" H2O Droop 2" H2O Boost*	5	268	419	565	629	689	996	1307	1342	
	10	356	618	870	892	910	1205	1503		
	20	469	872	1266	1376	656				
	40	730	1224	1707	2010					
	60	963	1447	1926			Flow in this area is outside the operating parameters of the valve			
	80	1255	1455	1627						
	100	1534	1763							
7" H2O (4-10" H2O) 1" H2O Droop 2" H2O Boost*	5	283	378	477	524	565	793	1024	848	
	10	380	585	791	722	653	1003	1345		
	20	488	871	1247	1684	2110	2177			
	35	673	1444	2188	2358	2525	3155			
	75	1221	2278	3317			Flow in this area is outside the operating parameters of the valve			
	90	1399	2623							
	100	1534	2836							
28" H2O (5-30" H2O) 5-1/2" H2O Droop	5	318	478	636	760	883	991	1095	1130	
	10	388	613	831	1128	1424	1584	1741		
	30	373	1074	1756	2192	2608	2834			
	45	718	1596	2393	2892			Flow in this area is outside the operating parameters of the valve		
	60	929	2121	3302	3294					
	75	1139	2517							
	100	1449	3219							
1.25 psi (0.5 - 1.75 psi) 0.2 psi Droop	5	198	299	482	434	578	511	723	1012	
	10	267	378	593	608	890	756	1038	964	
	30	328	552	969	924	1193	1342			
	45	479	758	1197	1157	1396		Flow in this area is outside the operating parameters of the valve		
	60	624	998	1497	1398	1622				
	75	689	1229	1858						
	100	920	1609	2376						
3 psi (1 - 3.5 psi) 0.3 psi Droop	5	159	238	318	346	371	408	442	742	
	10	237	355	475	571	672	710	752	831	
	30	266	550	825	921	1011	1337			
	45	479	758	1097	1157	1157		Flow in this area is outside the operating parameters of the valve		
	60	619	998	1376	1398	1410				
	75	689	1229	1708						
	100	852	1609	2387						
150	1100	2091	3081							

\* Boost refers to a small rise in outlet pressure set point that can occur, and is characteristic of, this type of regulator when flow nears the valve's maximum capacity. To understand this phenomenon and to determine your maximum flow requirements, see API 2000

## 1" N<sub>2</sub> FLOW CAPACITY: NM3/H

**To select the orifice size for your valve you need to know P1 (inlet pressure), P2 (outlet pressure set point), and maximum flow in NM3/H.**

1. Select the row that best represents your outlet Set Pressure (P2)
2. Select the sub-row that is representative of your Inlet Pressure (P1)
3. Find the Flow rate in that sub-row that encompasses your maximum flow. Look at the orifice column heading to determine your specific orifice size.

Set Pressure	Inlet (bar)	Orifice Size								
		1/8"	3/16"	1/4"	5/16"	3/8"	7/16"	1/2"	9/16"	
2" H2O (1-2.5" H2O)  1" H2O Droop 2" H2O Boost*	0.345	6.40	11.9	13.7	17.8	15.2	28.2	33.2	37.2	
	0.689	9.28	17.5	19.9	25.3	22.0	34.1	41.0		
	1.38	14.0	24.7	29.9	38.9	22.7				
	2.76	22.2	34.6	47.6	56.9					
	4.14	30.4	41.0	53.0			Flow in this area is outside the operating parameters of the valve			
	5.52	38.5	41.2	53.7						
	6.89	46.6	49.9							
10.3	60.7	63.8								
3" H2O (2-5" H2O)  1" H2O Droop 2" H2O Boost*	0.345	7.58	11.9	16.0	17.8	19.5	28.2	37.0	38.0	
	0.689	10.1	17.5	24.6	25.2	25.8	34.1	42.5		
	1.38	13.3	24.7	35.8	38.9	18.6				
	2.76	20.7	34.6	48.3	56.9					
	4.14	27.3	41.0	54.5			Flow in this area is outside the operating parameters of the valve			
	5.52	35.5	41.2	46.0						
	6.89	43.4	49.9							
10.3	56.1	63.8								
7" H2O (4-10" H2O)  1" H2O Droop 2" H2O Boost*	0.345	8.01	10.7	13.5	14.8	16.0	22.4	29.0	24.0	
	0.689	10.8	16.6	22.4	20.4	18.5	28.4	38.1		
	1.38	13.8	24.7	35.3	47.7	59.47	61.6			
	2.41	19.1	40.9	61.9	66.7	71.5	89.3			
	5.17	34.6	64.5	93.9			Flow in this area is outside the operating parameters of the valve			
	6.21	39.6	74.2							
	6.89	43.4	80.3							
10.3	56.1	104								
28" H2O (5-30" H2O)  5-1/2" H2O Droop	0.345	9.00	13.5	18.0	21.5	25.0	28.1	31.0	32.0	
	0.689	11.0	17.6	23.5	31.9	40.3	44.8	49.3		
	2.07	10.6	30.4	49.7	62.0	73.8	80.2			
	3.10	20.3	45.2	67.7	81.8					
	4.14	26.3	60.0	93.5	93.2		Flow in this area is outside the operating parameters of the valve			
	5.17	32.2	71.2							
	6.89	41.0	91.1							
10.3	53.0	118								
0,09 bar (0,03 - 0,12 bar)  0,01 bar Droop	0.345	5.6	8.46	13.6	12.3	16.4	14.5	20.5	20.5	
	0.689	7.56	10.7	16.8	17.2	25.2	21.4	29.4	29.4	
	2.07	9.28	15.6	27.4	26.2	33.8	38.0			
	3.10	13.6	21.5	33.9	32.7	39.5				
	4.14	17.7	28.2	42.4	39.6	45.9		Flow in this area is outside the operating parameters of the valve		
	5.17	19.5	34.8	52.6						
	6.89	26.0	45.5	67.2						
10.3	34.3	59.2	87.2							
0,21 bar (0,07 - 0,24 bar)  0,02 bar Droop	0.345	4.5	6.74	9.0	9.8	10.5	11.6	12.5	21.0	
	0.689	6.7	10.0	13.4	16.2	19.0	20.1	21.3	23.5	
	2.07	7.53	15.6	23.4	26.1	28.6	37.8			
	3.10	7.90	21.5	31.1	32.7	32.7				
	4.14	17.5	28.2	38.9	39.6	39.9		Flow in this area is outside the operating parameters of the valve		
	5.17	19.5	34.8	48.3						
	6.89	24.1	45.5	67.6						
10.3	31.1	59.2	87.2							

\* Boost refers to a small rise in outlet pressure set point that can occur, and is characteristic of, this type of regulator when flow nears the valve's maximum capacity. To understand this phenomenon and to determine your maximum flow requirements, see API 2000

# MARK 968 SANITARY GAS REGULATOR

## DIMENSIONS

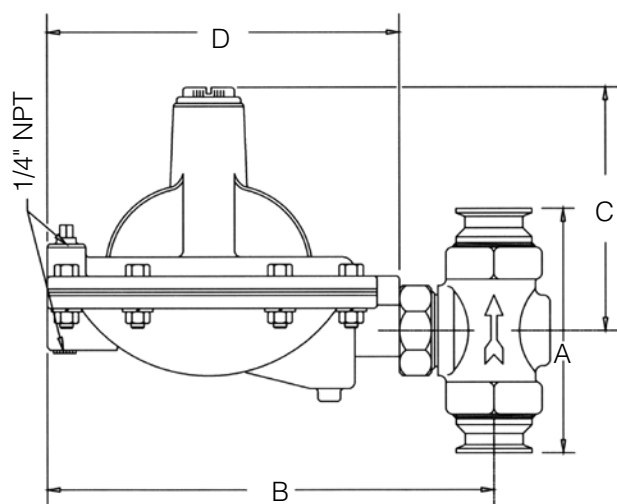

Valve Size	Dimensions, Inches			
	A	B	C	D
3/4"	5.88	11.31	5.75	9.00
1"	5.88	11.31	5.75	9.00

Valve Size	Dimensions, Mm			
	A	B	C	D
DN20	149,4	287,3	146,1	228,6
DN25	149,4	287,3	146,1	228,6

## ORDERING SCHEMATIC (3/4" - 1")

Model	Size	Material	/	1&2	3&4	5&6	7&8
—	—	—					

Model	
968	Mark 968 Sanitary Gas Regulator
Size	
075	3/4" (DN20)
100	1" (DN25)
Body Material	
S6	Stainless Steel
1&2	Connections & Body Finish
TC	Tri Clamp - Electropolished Finish
CT	Tri-Clamp - Standard Finish
DC	DIN - Tri Clamp - Electropolished Finish
CD	DIN - Tri-Clamp - Standard Finish
SC	ISO - Tri Clamp - Electropolished Finish
CS	ISO - Tri-Clamp - Standard Finish
ZZ	Non-Standard

3&4	Orifice Finish		
	Standard	Electropolish	
10	1/8" (3mm)	01	1/8" (3mm)
20	3/16" (5mm)	02	3/16" (5mm)
30	1/4" (6mm)	03	1/4" (6mm)
40	5/16" (8mm)	04	5/16" (8mm)
50	3/8" (10mm)	05	3/8" (10mm)
60	7/16" (11mm)	06	7/16" (11mm)
70	1/2" (13mm)	07	1/2" (13mm)
80	9/16" (14mm)	08	9/16" (14mm)
ZZ	Non-Standard	ZZ	Non-Standard

5&6	Range
01	1"-2.5" W.C. (2,5-6,2 mbar)
02	2"-5.5" W.C. (5,0-13,7 mbar)
03	4"-10" W.C. (10,0-24,9 mbar)
04	5"-30" W.C. (12,4-74,7 mbar)
05	0.5-1.75 psi (0,03-0,12 bar)
06	1-3.5 psi (0,07-0,24 bar)
ZZ	Non-Standard

7&8	Actuator Finish & Diaphragm
SD	Electropolished w/Viton (FDA)
DS	Standard w/Viton (FDA)
ZZ	Non-Standard

# Mark 968 Series

## Sanitary Gas Regulator (1-1/2" – 2")

The 1-1/2" and 2" valves are for use on large tank blanketing applications or other low pressure gas regulation. In a tank blanketing application, the Mark 968 is used to control the flow of the blanketing gas into the tank to maintain the proper positive pressure. Once the blanket has been established, a small flow of nitrogen is continually admitted to the tank to keep the blanket fresh. These valves are often used in conjunction with the Mark 958 back pressure gas regulator, used to vent gas from the tank to prevent blanketing pressure from rising to a level that could damage the tank.

The Mark 968 comes standard with an extra large diaphragm to give set point control as low as 2.0" W.C. (4,98 mbar). In addition, the "S" pattern body design allows for high flow capacity and bubble tight shutoff.

### SPECIFICATIONS

**Line Sizes:** 1-1/2" (DN40), 2" (DN50)

#### End Connections

- Clamp — ISO, DIN, Tri-Clamp
- Flanged — 150#, 300#, Sanitary
- Others upon request

#### Materials

- Body: Stainless Steel (SA351/CF8M)
- Trim: 316/316L Stainless Steel
- Seat: 316/316L Stainless Steel with Viton (FDA)
- Diaphragm: Viton (FDA)

**Shutoff:** ANSI Class VI

#### Ranges:

- 2 to 5 inches w.c. (4,98 to 12,5 mbar)
- 4 to 8 inches w.c. (9,96 to 19,93 mbar)
- 8 to 28 inches w.c. (19,93 to 69,75 mbar)
- 10 to 17 inches w.c. (24,91 to 42,35 mbar)
- 14 to 28 inches w.c. (34,87 to 69,75 mbar)
- 0.75 to 1 psi (51,71 to 68,95 mbar)
- 1 to 2 psi (68,95 to 137,90 mbar)
- 1.5 to 3 psi (0,10 to 0,21 bar)
- 3 to 5 psi (0,21 to 0,34 bar)

**Cv Rating:** 23 (20 Kv)

**Pressure Temperature Rating:** 25 psi @ 100°F (1,72 bar @ 27,8 °C), 25 psi @ 275°F (1,72 bar @ 135°C)

**Maximum Pressure Drop:** 25 psig (1,72 bar)

### DIMENSIONS

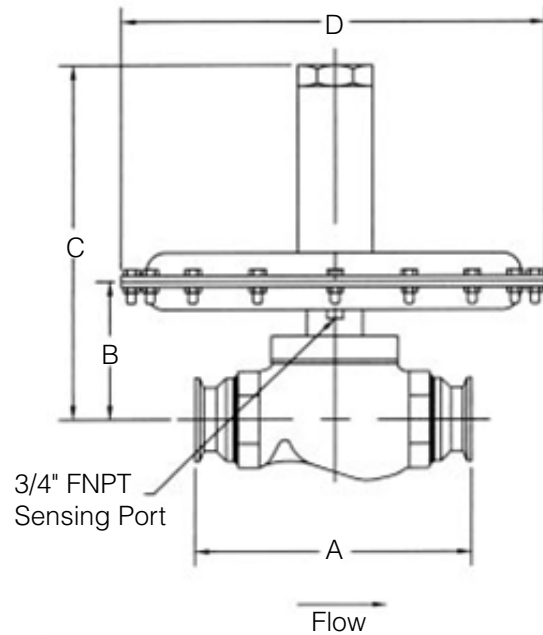

Valve Size	Dimensions, Inches			
	A	B	C	D
1-1/2"	8.75	4.93	12.32	15.00
2"	8.75	4.93	12.32	15.00

Valve Size	Dimensions, Inches			
	A	B	C	D
DN40	222,3	125,2	312,9	381,0
DN50	222,3	125,2	312,9	381,0

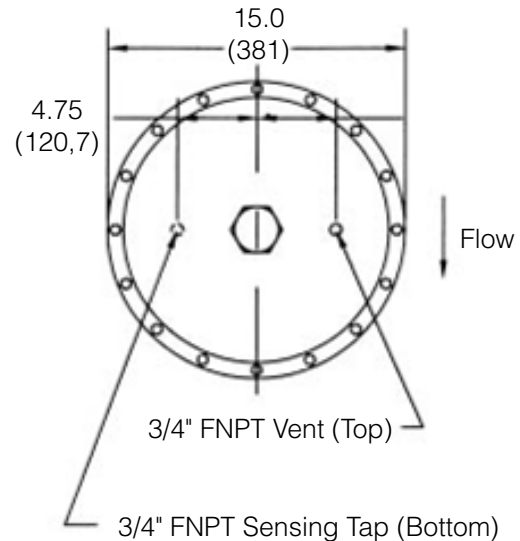

MARK 968 SANITARY GAS REGULATOR

1-1/2" N<sub>2</sub> FLOW CAPACITIES: SCFH (SHADED), NM<sup>3</sup>/H (UNSHADED)

To find the maximum flow rate that this valve can control to, you need to know P1 (inlet pressure), P2 (outlet pressure set point), and maximum flow in SCFH.

1. Select the Range row that encompasses your outlet Set Pressure (P2).
2. Select the sub-row that is closest to your actual outlet Set Pressure (P2)
3. Select the column that best represents your Inlet Pressure (P1).
4. The maximum flow rate that the valve can regulate is the number represented at the intersection of the sub row and the Inlet Pressure column.

Range	Outlet Pressure Set Point	Accuracy	Inlet Pressure							
			2.0 psi (0,14 bar)	3.0 psi (0,21 bar)	5.0 psi (0,34 bar)	10.0 psi (0,69 bar)	15.0 psi (1,03 bar)	20.0 psi (1,38 bar)	25.0 psi (1,72 bar)	
2.0-5.0" WC	3.0" WC	0.75" WC	4853	5185	5999					
4,98-12,5 mbar	7,47 mbar	1,87 mbar	137	147	170					
4.0-8.0" WC	5.0" WC	1" WC	4675	5532	6748	8599				
	7.0" WC		4987	5747	6482	6984				
9,96-19,93 mbar	12,45 mbar	2,49 mbar	132	157	191	243				
	17,44 mbar		141	163	184	198				
8.0-28.0" WC	10.0" WC	1.5" WC	5601	5297	6622	7720	8468	7638		
	25.0" WC		4293	4672	4357	4858	6876	7220		
19,93-69,75 mbar	24,91 mbar	3,74 mbar	159	150	188	219	240	216		
	62,27 mbar		122	132	123	138	195	204		
10.0-17.0" WC	12.0" WC	2" WC	4582	5984	7169	10367	10228	10838		
	15.0" WC		4297	5200	7111	9778	10310	10748		
24,91-42,35 mbar	28,89 mbar	4,98 mbar	130	169	203	294	290	307		
	37,36 mbar		122	147	201	277	292	304		
14.0-28.0" WC	15.0" WC	2.5" WC	4070	5737	8261	10811	12068	13414	13120	
	25.0" WC		3123	4487	6675	9057	10792	11608	12938	
34,87-69,75 mbar	37,36 mbar	6,23 mbar	115	162	234	306	342	380	372	
	62,27 mbar		88	127	189	256	306	329	366	
0.75-1 psi	0.75 psi	0.25 psi	4843	7253	9628	11573	13833	15278	17038	
	1 psi		4638	6286	9501	11557	13892	15253	17026	
51,71-68,95 mbar	51,71 mbar	12,93 bar	137	205	273	328	392	433	482	
	68,75 mbar		131	178	269	327	393	432	482	
1-2 psi	1.5 psi	0.3 psi		4352	8736	11529	13957	15514	17358	
	2.0 psi			3505	7588	11281	13764	15351	17206	
68,95-137,0 mbar	0,10 bar	20,69 mbar		123	247	326	395	439	492	
	0,14 bar			99	215	319	390	435	487	
1.5-3 psi	2.0 psi	0.4 psi		3929	8034	11339	13871	15466	17332	
	3.0 psi				6057	10924	13626	15327	17252	
0.10-0,21 bar	0,14 bar	27,50 mbar		111	228	321	393	438	491	
	0,21 bar				172	309	386	434	489	
3-5 psi	3.5 psi	0.5 psi			3507	10781	13598	15365	17332	
	5.0 psi					9639	12792	14682	16688	
0,21-0,34 bar	0,24 bar	34,38 mbar			99	305	385	435	491	
	0,34 bar					273	362	416	473	

Nitrogen at 0.97 s.g. in scfh and Nm<sup>3</sup>/h.

Operation in shaded areas not recommended.

## 2" N<sub>2</sub> FLOW CAPACITIES: SCFH (SHADED), NM<sup>3</sup>/H (UNSHADED)

To find the maximum flow rate that this valve can control to, you need to know P1 (inlet pressure), P2 (outlet pressure set point), and maximum flow in SCFH.

1. Select the Range row that encompasses your outlet Set Pressure (P2).
2. Select the sub-row that is closest to your actual outlet Set Pressure (P2)
3. Select the column that best represents your Inlet Pressure (P1).
4. The maximum flow rate that the valve can regulate is the number represented at the intersection of the sub row and the Inlet Pressure column.

Range	Outlet Pressure Set Point	Accuracy	Inlet Pressure									
			2.0 psi (0,14 bar)	3.0 psi (0,21 bar)	5.0 psi (0,34 bar)	10.0 psi (0,69 bar)	15.0 psi (1,03 bar)	20.0 psi (1,38 bar)	25.0 psi (1,72 bar)			
2.0-5.0" WC	3.0" WC	0.75" WC	5392	5761	6666							
4,98-12,5 mbar	7,47 mbar	1,87 mbar	153	163	189							
4.0-8.0" WC	5.0" WC	1" WC	5195	6147	7498	9554	Flow in this area is outside the operating parameters of the valve					
	7.0" WC		5541	6385	7202	7760						
9,96-19,93 mbar	12,45 mbar	2,49 mbar	147	174	212	271						
	17,44 mbar		157	181	204	220						
8.0-28.0" WC	10.0" WC	1.5" WC	6223	5885	7358	8578					9408	8486
	25.0" WC		4770	5191	4841	5398					7640	8022
19,93-69,75 mbar	24,91 mbar	3,74 mbar	176	167	208	243	266	240				
	62,27 mbar		135	147	137	153	216	227				
10.0-17.0" WC	12.0" WC	2" WC	5091	6649	7965	11519	11365	12042				
	15.0" WC		4775	5778	7901	10864	11456	11942				
24,91-42,35 mbar	28,89 mbar	4,98 mbar	144	188	226	326	322	341				
	37,36 mbar		135	164	224	308	324	338				
14.0-28.0" WC	15.0" WC	2.5" WC	4523	6374	9179	12013	13409	14904	14578			
	25.0" WC		3470	4986	7416	10063	11991	12898	14376			
34,87-69,75 mbar	37,36 mbar	6,23 mbar	128	180	260	340	380	422	413			
	62,27 mbar		98	141	210	285	340	365	407			
0.75-1 psi	0.75 psi	0.25 psi	5382	8059	10698	12859	15370	16976	18931			
	1 psi		5153	6984	10556	12841	15436	16948	18918			
51,71-68,95 mbar	51,71 mbar	12,93 bar	152	228	303	364	435	481	536			
	68,75 mbar		146	198	299	364	437	480	536			
1-2 psi	1.5 psi	0.3 psi		4835	9706	12810	15508	17238	19286			
	2.0 psi			3895	8431	12534	15293	17056	19118			
68,95-137,0 mbar	0,10 bar	20,69 mbar		137	275	363	439	488	546			
	0,14 bar			110	239	355	433	483	541			
1.5-3 psi	2.0 psi	0.4 psi		4365	8927	12599	15412	17185	19258			
	3.0 psi				6731	12138	15140	17030	19169			
0.10-0,21 bar	0,14 bar	27,50 mbar		124	253	357	436	487	545			
	0,21 bar				191	344	429	482	543			
3-5 psi	3.5 psi	0.5 psi			3897	11979	15109	17072	19258			
	5.0 psi					10710	14214	16314	18543			
0,21-0,34 bar	0,24 bar	34,38 mbar			110	339	428	483	545			
	0,34 bar					303	402	462	525			

Nitrogen at 0.97 s.g. in scfh and Nm<sup>3</sup>/h.

Operation in shaded areas not recommended.

**ORDERING SCHEMATIC (1-1/2" – 2")**

Model	Size	Material	/	1&2	3&4	5&6	7&8	9&10
	—	—						

Model	
968	Mark 968 Sanitary Gas Regulator

Size	
150	1-1/2" (DN40)
200	2" (DN50)

Body Material	
S6	Stainless Steel

1&2	Connections & Body Finish
TC	Tri Clamp - Electropolished Finish
CT	Tri-Clamp - Standard Finish
DC	DIN - Tri Clamp - Electropolished Finish
CD	DIN - Tri-Clamp - Standard Finish
SC	ISO - Tri Clamp - Electropolished Finish
CS	ISO - Tri-Clamp - Standard Finish
ZZ	Non-Standard

3&4	Seat & Diaphragm / Seat Finish
VN	Viton / Electropolished Seat
NV	Viton / Standard Finish Seat

5&6	Range
07	2-5" WC (4,98-12,5 mbar)
08	4-8" WC (9,96-19,93 mbar)
09	8-28" WC (19,93-69,75 mbar)
10	10-17" WC (24,91-42,35 mbar)
11	14-28" WC (34,87-69,75 mbar)
12	0.75-1 psi (51,71-68,95 mbar)
13	1-2 psi (68,95-137,90 mbar)
14	1.5-3 psi (0,10-0,21 bar)
15	3-5 psi (0,21-0,34 bar)
ZZ	Non-Standard

7&8	Actuator Finish
SD	Electropolished
DS	Standard
ZZ	Non-Standard

9&10	Bushing
TF	Teflon-FDA
ZZ	Non-Standard



**Steriflow, a division of Jordan Valve**

3170 Wasson Road • Cincinnati, OH 45209  
 513.533.5600 • 800.543.7311 • 513.871.0105 (f)  
 steriflow@richardsind.com • www.steriflowvalve.com

*Steriflow Valve reserves the right to make revisions to its product, specifications, literature and related information without notice. Please visit our website at [www.steriflowvalve.com](http://www.steriflowvalve.com) for the latest information on our products.*