



**STERIFLOW**  
a division of Jordan Valve

3170 Wasson Road • Cincinnati, OH 45209 USA  
Phone 513-533-5600 • Fax 513-871-0105  
steriflow@richardsind.com • www.steriflowvalve.com

## I & M Mark 978

### Installation & Maintenance Instructions for Mark 978 Sanitary Control Valve

#### Please read these instructions carefully!

Your Steriflow product will provide you with long, trouble free service if it is correctly installed and maintained. Spending a few minutes now reading these instructions can save hours of trouble and downtime later. When making repairs, use only genuine Steriflow Valve parts, available for immediate shipment from the factory.

#### Valve Installation

1. The Valve is designed for sanitary service and should be installed in a clean system. As such, strainers at the valve inlet to protect the valve should not be necessary.
2. For **angle body valves**, the valve is normally installed with inlet vertical on the bottom, and outlet horizontal to provide the best drainage inside the valve. This is recommended only for drainage considerations: the valve will function in any position. For optional **INLINE Series valves**, the valve must be installed on horizontal pipe in an upright position with the top plane of the actuator parallel to the floor.
3. Steam control valves are best located at a high point in the piping system with the take-off out of the top of the steam header. This minimizes the possibility of water in the valve.
4. For best control, 3'0" straight sections of pipe should be installed on either side of the valve.
5. Use caution in tightening commercial sanitary fittings. Over-tightening can cause the gasket to extrude into the flow passage.
6. If possible, install a relief valve downstream from the MK978. Set at about 15% above the control pressure.
7. In gas or vapor service, select outlet piping at least one pipe size larger than the inlet.
8. Operate the MK978 within pressure/temperature ratings on the nameplate. Refer to catalog for additional details.
9. Provide proper air pressure to actuator. Valves with positioners: 20 psig supply for 3-15 range, 40 psig supply for 6-30 range; valves without positioners: 40 psig supply to controller.

#### Start-Up

1. Make sure actions of control valve and controller are such as to give desired results as shown in the following table. To change the action, see instructions under Actuator Subassembly.

#### Controller Action

If increase in pressure or temperature must:	And the action of the valve is:	Then the action of the controller must be:
Close Valve	Air-to-Close	Direct
	Air-to-Open	Reverse
Open Valve	Air-to-Close	Reverse
	Air-to-Open	Direct

The Mark 978 has been pre-set at the factory. However, finer adjustments may be required to compensate for pressure drop conditions of the application.

2. With the inlet, outlet, and bypass shutoff valves closed, and no pressure in the downstream line, fully open the outlet shutoff valve. Slowly open the inlet valve just enough to start flow through the MK978. Increase flow gradually by slowly opening the inlet shutoff valve. Do not fully open the inlet valve until you are sure that the controller and control valve have control of the system. Usually, the handwheel on the inlet valve will turn freely once this point is reached.
3. To shutoff the line fluid, close the inlet shutoff valve first, followed by the outlet shutoff valve.

#### Preparing for Maintenance

**Warning: be sure that there is not pressure in the valve before loosening any fitting or joint.**

1. Close inlet shutoff valve and bypass valve.
2. Open the MK978.
3. Allow pressure to bleed off downstream.
4. When pressure gauge shows there is no pressure in the valve, close outlet shutoff valve.
5. When lubricant is needed, use one that is compatible with both your process and the valve's seal material (see nameplate). Jordan uses, and recommends, Bostic NEVER-SEEZ, white food grade with PTFE, catalog #NSWT-14 (improved version without mineral oils). Refer to appropriate drawings when performing maintenance.

#### Seal Replacement

The MK978 can be ordered with two different diaphragm seals: an o-ring version with a gasket to seal the body to bonnet joint, and a diaphragm sealed version with an o-ring backup.

### Body / Bonnet Gasket Replacement

1. The Mark 978 must be in open position, plug (41) off seat. For reverse acting valves, apply pressure to actuator to lift plug off seat.
2. Remove bonnet bolts (22) and separate body (1) from bonnet (3).
3. Remove the old gasket. Lubricate sealing surface in body, install new gasket, and reassemble.

**Note: For normally closed valves, retract stem with air pressure in actuator to reassemble easily.**

### Stem O-Ring

1. MK978 must be in open position, plug (11) off seat. Reverse acting valves need pressure applied to actuator to lift plug off seat.
2. Remove bonnet bolts (22) and separate body (1) from bonnet (3).
3. Remove air pressure from actuator.
4. Remove the two cap screws (42) from the lower stem connector (25).
5. Loosen the lower jam nut (21), mark the point on the stem where it meets the lower stem connector, then remove the lower stem connector and jam nut. Pull the plug (11,41) downward and out of the bonnet.
6. Remove the bushing lock ring (7), stem bushing (2), and o-ring (19) using a hooked removal tool.
7. Replace the plug (11,41) by inserting it through the bottom of the bonnet (3). Lubricate and install new o-ring (19) in the bonnet (2).
8. Reinstall the stem bushing (2) and replace the bushing lock ring (7).

### Diaphragm Seal Replacement

1. Mark 978 must be in open position, plug (11) off seat. Reverse acting valves need pressure applied to actuator to lift plug off seat.
2. Remove bonnet bolts (22) and separate body (1) from bonnet (3).
3. Remove air pressure from actuator.
4. Remove the two cap screws (42) from the lower stem connector (25).
5. Loosen the lower jam nut (21), mark the point on the stem (10) where it meets the lower stem connector, then remove the lower stem connector and jam nut. Pull the plug/stem assembly (4,10,11) downward and out of the bonnet.
6. For soft seated valves: clean threads on the plug (11) and on the soft seat retainer (end of the plug that holds the soft seat material ring). Install new soft seat onto the retainer (or onto plug on some versions). Apply Loctite 2046 with Primer 7649 (following Loctite's instructions) to threads and thread the retainer back onto plug (11). Tighten until the screw threads run out.
7. Using soft jaw pliers or a strap wrench on the upper stem (10) and soft jaw pliers on the wrench flats of plug (11), break the threaded connection and remove old diaphragm (4). Clean and prime

- threads. Replace the old diaphragm and reassemble the plug/stem diaphragm using Loctite 2046 with Primer 7649 (following Loctite's instructions). Tighten until the mechanical stop is engaged and the diaphragm assumes an "umbrella" shape.
8. Replace the plug assembly (4,10,11) by inserting it through the bottom of the bonnet (2).
9. Reinstall the lower jam nut (21) and reconnect to the lower stem connector (25) referencing the index mark made in step 5 above to preserve bench set.
10. Replace bonnet on valve body (see step 1 above if valve is reverse acting).
11. Secure bonnet to body with bonnet bolts loosely tighten. Cycle the valve by stroking the plug up and down several times to align the trim to the body. With the plug on the seat, cross tighten bonnet bolts 150 in. - lbs. in two stages.

### Reassembly

1. For valves with reverse acting actuators, apply air pressure to actuator to move actuator stem up into actuator.
2. Screw the jam nut (21) and lower stem connector (25) back on to the valve stem (10,41) to match the insertion mark made earlier and lock with jam nut (21). Reinstall the two stem connector cap screws (42).
3. Assemble bonnet (3) to body (1) and secure with bolts (22).

---

## Actuator

---

### Actuator Disassembly – Reverse Acting

1. Apply sufficient air pressure to lift plug (11,41) off seat. Separate body and bonnet.
2. Loosen and remove yoke lock ring (8).
3. Remove the two stem connector cap screws (42). Loosen the upper jam nut (20), mark the point where the actuator stem (23) meets the upper stem connector (24). Remove the upper stem connector (24) and jam nut (20) from actuator stem (23).
4. Remove air pressure from actuator.
5. Remove housing nuts, bolts and washers (16,17,18) then separate upper and lower housings (13,12).
6. Remove springs (14).
7. Hold actuator stem (23) with a wrench on the flats on its lower end and remove the cap screw (5).
8. Remove in order: spacer (37 - used only 55M & 85M), diaphragm plate (15), diaphragm (9), spacer (27 - 85M only) seal washer/thread seal (30,31).
9. Remove the gland nut (34), gland (32), o-ring (35), and bushing (36).

### Actuator Disassembly – Direct Acting

1. Loosen and remove the yoke lock ring (8).
2. Remove the two stem connector cap screws (42). Loosen the upper jam nut (20), mark the point where the actuator stem meets the upper stem

- connector (24). Remove the upper stem connector (24) and jam nut (20) from actuator stem (23) and remove actuator.
3. Remove housing cap nuts, bolts and washers (16,17,18) and separate upper and lower housings (12,13).
  4. Hold actuator stem (23) with a wrench on the flats on its lower end and remove cap screw (5).
  5. Remove in order: Thread seal and seal washer (30,31), diaphragm (9), diaphragm plate (15), spacer (37 - 55M/85M only), springs (14).
  6. Remove gland nut (34), bushing (36), and o-ring (35).
  7. Remove gland (30), gland gasket (33) and stem (23).

---

## Actuator Reassembly

---

All actuators have field reversible action. To reverse the action, follow reassembly procedure for desired action.

### Reverse Acting

1. Place gasket (33 - do not grease) over the gland (32) and insert gland through hole in lower actuator case (12) from the inside to the outside. Lightly grease stem o-ring (35), and bushing (36) and install in the counter bore of the gland o-ring first. Thread gland nut (34) onto the gland (32) and tighten.
2. Taking care not to cut o-ring, insert actuator stem (23) through the gland from the outside so wrench flats are outside the actuator case.
3. Place seal washer with thread seal (30,31) on the actuator stem (23) with thread seal facing the actuator stem and gland.
4. Assemble the spacer (37 - 85M only), diaphragm (9), diaphragm plate (15), and cap screw (5). Tighten.
5. Align bolt holes in the diaphragm with holes in lower actuator case.
6. Replace springs over bosses in diaphragm plate.
7. Reinstall actuator bolts, nuts and washers.

### Direct Acting

1. Place gasket (33 - do not grease) over the gland (32) and insert gland through hole in lower actuator case (12) from the inside to the outside. Lightly grease the stem o-ring (35), and bushing (36) and install in counter bore of the gland. Thread the gland nut (34) onto the gland (32) and tighten.
2. Assemble actuator stem (23), seal washer with thread seal (30,31) toward diaphragm (9), and spacer (37 - only on 55M & 85M) with the actuator bolt (5) and tighten.
3. Hold cap screw by its head in vise, actuator stem point up.
4. Install springs (14) over dimples in diaphragm plate.
5. Taking care not to cut o-ring, insert actuator stem (23) through gland from the outside so the wrench flats are outside the actuator case.

6. Place the upper actuator case (13) on the diaphragm in alignment with the bolt holes.
7. Place four nuts, bolts and washers (16,17,18) 90° apart and tighten finger tight. Install remaining bolts and nuts evenly while alternating across the actuator case.

---

## Troubleshooting

---

### If You Experience Erratic Control:

- Oversizing can cause cycling or hunting – recalculate required Cv.
- Undersizing can cause the control point to drop off under peak loads – increase trim size.
- Inlet pressure may be varying significantly and the controller may not be following it – adjust controller.
- Improper trim characteristic.
- Steam traps may need reconditioning.
- Safety relief valves may be leaking.
- Valve stroke may be out of adjustment or there may be foreign matter in the valve preventing full plug movement.

### If You Experience Insufficient Flow:

- Check shutoff valves to be sure they are fully open.
- Inlet pressure to the valve may be insufficient to provide the needed flow – check the inlet pressure with a pressure gauge.
- Steam traps may need reconditioning; foreign material in the trim may prevent the valve from passing its full capacity.
- Diaphragm failure, insufficient air pressure, or incorrect actuator spring adjustment in reverse acting (air to open) actuators will prevent the valve from properly open.

### If You Experience Overpressure (Outlet):

- Foreign material in the trim can prevent the valve from shutting off.
- Diaphragm failure, insufficient air pressure, or incorrect actuator spring adjustment in direction acting (air to close) actuators will prevent the valve from properly stroking closed.
- Hard seated valves may not be capable of tight shutoff (leakage would cause downstream pressure to rise).
- Overranging the valve – use smaller Cv.

### If You Experience Leakage:

- Excessive pressure drop across the valve could prevent the valve from shutting off properly – check the catalog ratings for the maximum allowable pressure drop for your trim, action and actuator.
- Hard seated valves may not be capable of tight shutoff (leakage would cause downstream pressure to rise).
- Overranging the valve – use smaller Cv.

## Illustration and Parts List

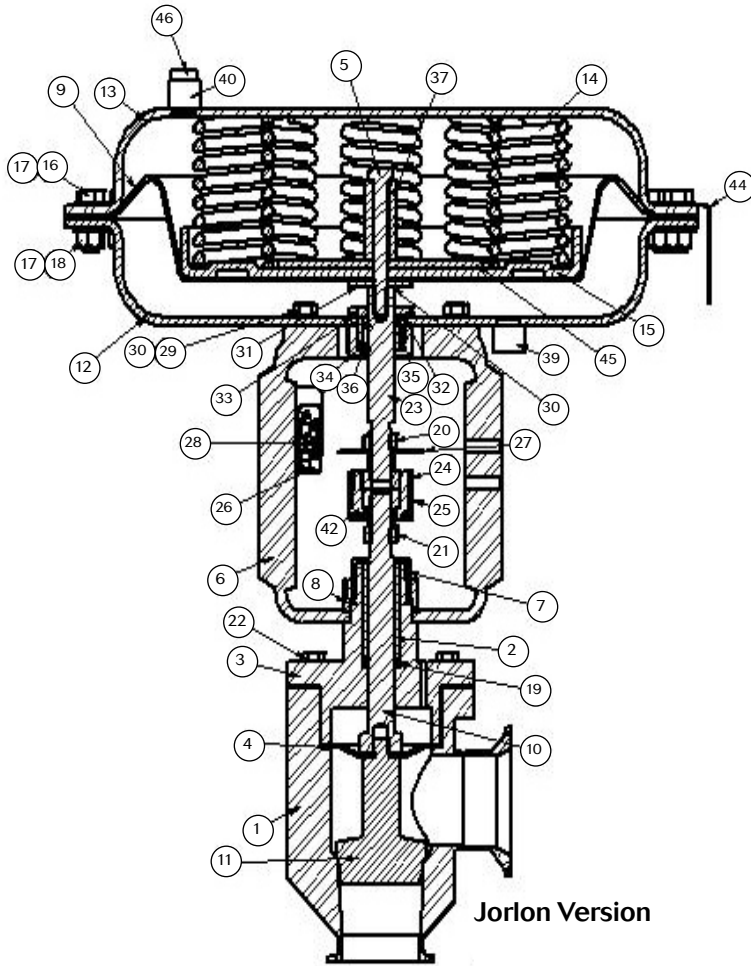

**Jorlon Version**

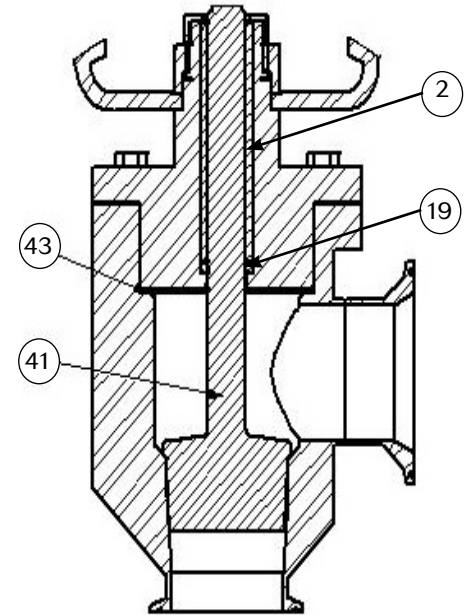

**O-Ring Version**

Item	Description	Item	Description	Item	Description
1	Body	16	HHCS	31	Seal Washer
*2	Stem Bushing	17	Washer	32	Gland
3	Bonnet	18	Nut	33	Gland Gasket
*4	Diaphragm, Body	*19	Stem O-Ring	34	Gland Nut
5	HHCS	20	Jam Nut	35	Gland O-Ring
6	Yoke	21	Jam Nut	36	Gland Bushing
7	Lock Ring, Bushing	22	HHCS	37	Spacer (55M/85M)
8	Lock Ring, Yoke	23	Actuator Stem	39	Lower Case Bushing
9	Diaphragm, Actuator	24	Stem Connector, Upper	40	Upper Case Bushing
10	Upper Stem	25	Stem Connector, Lower	*41	Stem (OR Version)
*11	Plug	26	Travel Scale	42	SHCS
12	Lower Actuator Case	27	Travel Indicator	*43	Bonnet Gasket (OR Version)
13	Upper Actuator Case	28	RHMS	44	Steriflow Name Plate
14	Spring	29	HHCS	45	Backing Plate (85M)
15	Diaphragm Plate	30	Fastener Seal	46	Vent Plug
*	Recommended Spare Parts				