



3170 Wasson Road • Cincinnati, OH 45209 USA  
 Phone 513-533-5600 • Fax 513-871-0105  
 steriflow@richardsind.com • www.steriflowvalve.com

## I & M Mark 93 & 94 Series

### Installation & Maintenance Instructions for the Mark 93 & Mark 94 Sanitary Steam Traps

**Warning:** Steriflow Sanitary Steam Traps must only be used, installed and repaired in accordance with these Installation & Maintenance Instructions. Observe all applicable public and company codes and regulations. In the event of leakage or other malfunction, call a qualified service person; continued operation may cause system failure or a general hazard. Before servicing any valve, disconnect, shut off, or bypass all pressurized fluid.

### Please read these instructions carefully!

Your thermostatic style Mark 93 and Mark 94 Series of sanitary steam traps will provide you with long, trouble-free service if they are correctly installed and maintained. A few minutes of your time spent reading these instructions now may save hours of trouble and downtime later.

These sanitary traps offer 316L Stainless Steel bodies with Tri-Clamp® style ends and Tube Welded Ends. The replacement thermal element is easily accessed by way of the Tri-Clamp® style body joint. Body gasket is of Teflon encapsulated Viton.

### Ideal Installation

1. Blow or flush out piping per sanitary piping requirements to ensure no foreign materials are present.
2. Verify that your sanitary steam trap will meet system conditions by checking information lasered on the body for operating differential pressure and maximum pressure and temperature limits of the trap body.
3. These traps can operate in any position, but to be self-draining, the recommended installation is in a vertical pipe run with the inlet uppermost.
4. Isolation valves should always be installed on either side of the trap for service purposes.
5. For Process, Heating, or Dripleg applications, these thermostatic element traps should be located off of a condensate collecting pocket and below the condensate outlet of the equipment.
6. Install as per approved piping methods for sanitary systems as shown in the cutaway and exploded view illustrations.

### Installation & Operation

The Mark 93 and Mark 94 sanitary steam trap feature a simple thermostatic element of 316L construction that moves to close the valve seat when thermostatic forces expand the internal thermal fill. The trap bodies are self draining which is a requirement of sanitary steam traps.

The MK93 is suited for applications such as those of dripleg, tank or line sterilization, small plant process units and similar sanitary steam applications. The Mark 94 is suitable for heavier condensate loads.

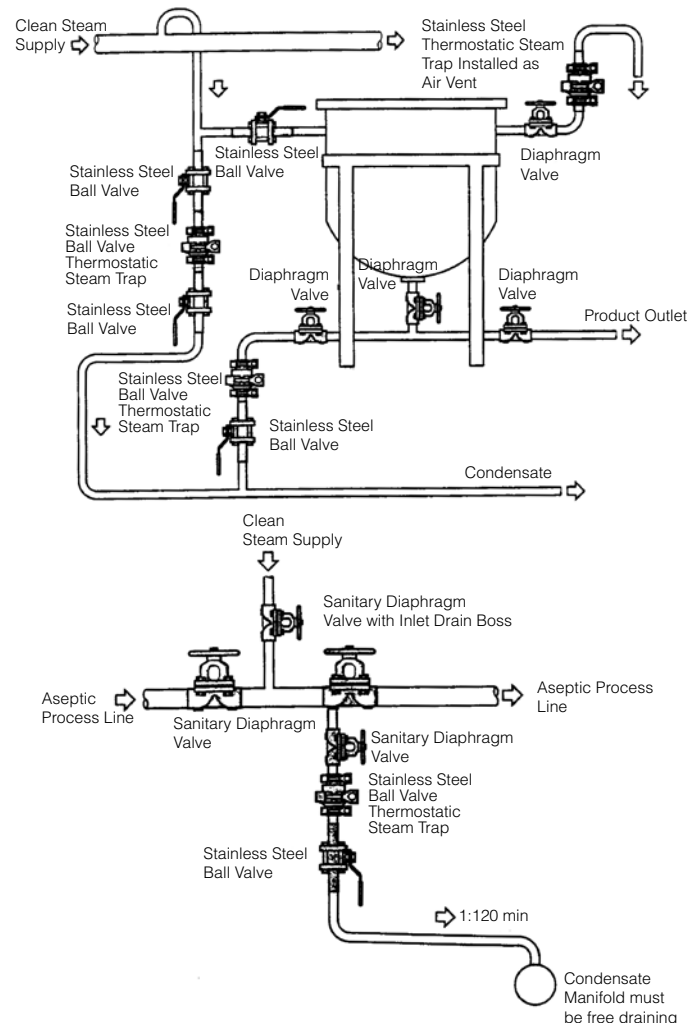

## Maintenance

1. Check that steam supply is shutoff. Ensure that all system pressures are off and trap is cool before opening.
2. Remove sanitary steam trap from the sanitary piping by disconnecting the inlet and outlet Tri-Clamps® and slipping the trap from the line.
3. The trap can then be easily dismantled by removing the Tri-Clamp® holding the two body components together. Separate the inlet and outlet halves of the body and the thermal element is readily accessible.
4. Inspect and clean the components per sanitary application requirements.
5. Inspect for any damage or wear to the thermal element seating surfaces and the valve seat areas of the trap body outlet half.
6. Replace the trap's thermal element if poor operation is suspected.
7. Reassemble the trap components as shown in the cut-away illustration.
8. The body joint gasket is reusable unless leakage occurred, in which case install a new gasket.
9. Tighten Tri-Clamp® securing the body halves together.
10. Install trap in sanitary piping using proper gaskets and Tri-Clamp® connectors.

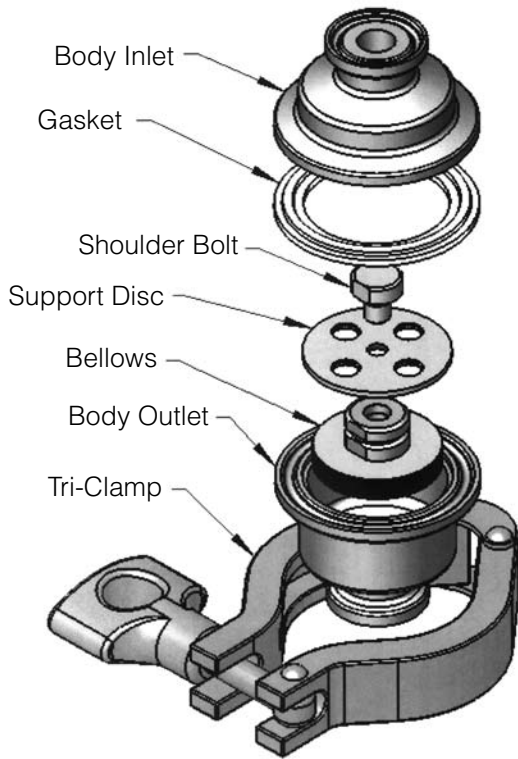

*Tri-Clamp Ends*

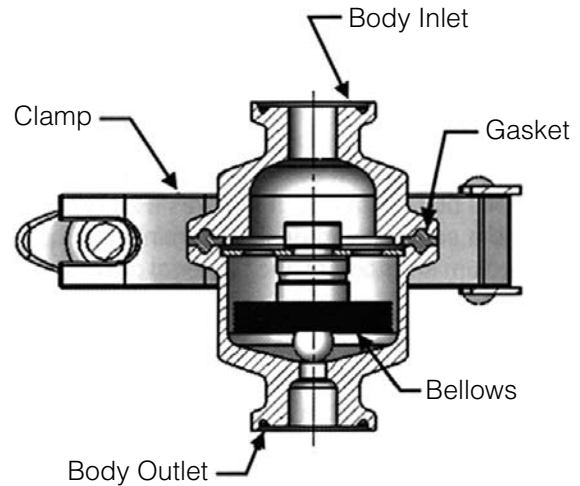

*Tube Weld Ends*

